

# **Kawasaki**

**Hydraulics**

# **K3VL**

**Axial Piston Pumps for  
Open Circuits in Mobile, Industrial  
and Marine Applications**

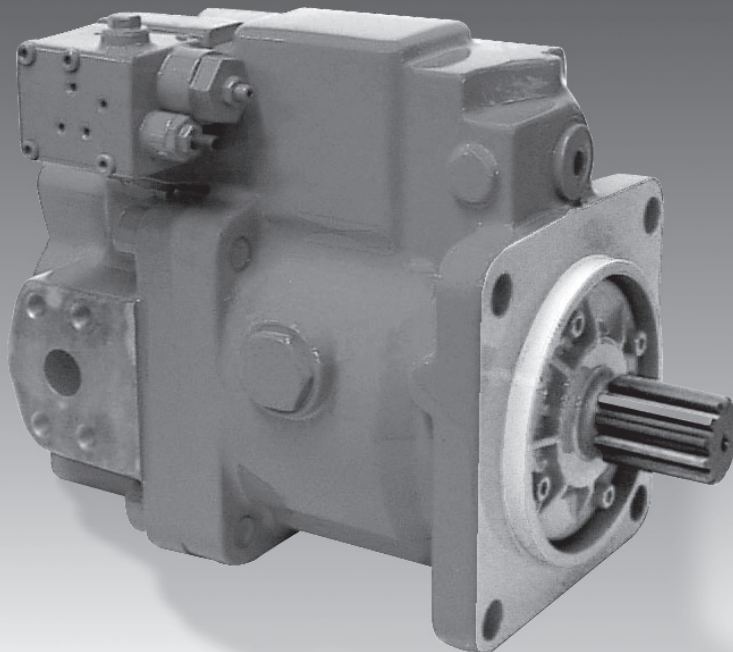

# Contents

1.	General Description .....	IFC
2.	Specifications .....	1
3.	Model Coding .....	2
4.	Functional Description of Regulators .....	4
5.	Performance Curves .....	9
	K3VL28 .....	9
	K3VL45 .....	10
	K3VL60 .....	11
	K3VL80 .....	12
	K3VL112 .....	13
	K3VL140 .....	14
	K3VL200 .....	15
6.	Mounting Precautions .....	16
7.	Filtration .....	17
8.	Hydraulic Fluid Requirements .....	17
9.	Initial Start-up .....	17
10.	Drive Shaft Coupling .....	17
11.	Installation Drawings .....	18
	K3VL28 .....	18
	K3VL45/60 .....	20
	K3VL80 .....	22
	K3VL112/140 .....	24
	K3VL200 .....	27
12.	Response Time .....	28
13.	Through Drives .....	29
14.	Pump Controls .....	32
15.	Integral Unloading Valve, Proportional Unloading Valve, Electronic Displacement Control .....	33
16.	Proportional Amplifier .....	BC

## 1.0 General Description

K3VL series swash-plate type axial piston pumps are designed to satisfy medium to heavy-duty open circuit applications in the mobile, industrial, marine and other industries. The pump's rotating groups are based upon the proven design of the K3V and K3VG pumps. K3VL pumps are available in nominal displacements ranging from 1.71 to 12.20 in<sup>3</sup>/rev (28 to 200 cc/rev) with various pressure, flow, and combination control options.

Key features of K3VL pumps include:

- Continuous pressure rating of 4600 psi (320 bar), 3625 psi (250 bar) for K3VL60.
- High overall efficiency (> 90% peak)
- Exceptional self priming capabilities.
- American (SAE) or European (ISO) mounting and shaft
- Excellent reliability and very long service life.
- High power to weight ratio.
- Numerous control options.
- Variety of optional through drives.
- Quick control response.
- Low pulsation and noise levels.
- Integral unloading valve or proportional pressure relief valve available

## 2.0 Specifications

Pump Model		K3VL28	K3VL45	K3VL60	K3VL80	K3VL112	K3VL140	K3VL200
Displacement - in <sup>3</sup> /rev (cc/rev)		1.71 (28)	2.75 (45)	3.66 (60)	4.88 (80)	6.83 (112)	8.54 (140)	12.20 (200)
Pressure Rating - psi (bar)	Rated	4600 (320)		3625 (250)	4600 (320)			5075 (350)
	<sup>1</sup> Peak	5075 (350)		4060 (280)	5075 (350)			5800 (400)
Speed Rating (rpm at Max. Displacement)	<sup>2</sup> Self Prime	3000	2700	2400	2400	2200	2200	1900
	<sup>3</sup> Maximum	3600	3250	3000	3000	2700	2500	2200
Minimum Operating Speed - rpm		600						
Maximum Allowable Case Drain Pressure - psi (bar)	Continuous	15 (1)						
	Peak	60 (4)						
Pump Case Prefill Capacity - Gallons (Liters)		0.16 (0.60)			0.21 (0.80)	0.37 (1.40)		.78 (3)
Weight - lb (kg)		44 (20)	55 (25)	55 (25)	77 (35)	143 (65)		220 (100)
Temperature Range - °F (°C)		-4° to 203° (-20° to 95°)						
<sup>4</sup> Viscosity Range - SUS (cSt)		55 to 4650 (10 to 1000)						
Maximum Contamination Level		20/18/15 ISO/DIS 4406 (Class 9)						
<sup>5</sup> Standard Mounting Flange and Shaft	Mounting	2-Bolt SAE B			2-Bolt SAE C	4-Bolt SAE D		4-Bolt SAE E
	Shaft	SAE B Spline or Key	SAE B-B Spline or Key		SAE C Spline or Key	SAE D Spline or Key		SAE D Spline or Key
Optional Mounting Flange and Shaft	Mounting	—	—		—	2-Bolt SAE C		—
	Shaft	—	SAE B Spline		—	SAE C or C-C Spline or Key		SAE F Spline
Input Shaft Torque Rating		Refer to to Table 2.1						
Through Drive Torque Rating - lb <sub>r</sub> -ft (Nm)	SAE A	45 (61)	90 (123)					
	SAE B	115 (155)	214 (290)		251 (340)			
	SAE B-B	—	214 (290)		406 (550)			
	SAE C	—	—		295 (400)	516 (700)	730 (990)	
	SAE C-C	—	—		—	516 (700)	730 (990)	
	SAE D	—	—		—	516 (700)	1032 (1400)	
	SAE E <sup>6</sup>	—	—		—	—	1032 (1400)	

\*1 The instant allowable surge pressure as defined by DIN24312. Life and durability of the pump will be affected.

\*2 Steady state inlet pressure should be greater than or equal to 0 psi (0 bar) gauge.

\*3 Steady state inlet pressure should be greater than or equal to 4.5 psi (0.3 bar) gauge. However the maximum charge pressure should not exceed 145 psi (10 bar).

\*4 At viscosities from 930 to 4650 SUS (200 to 1000 cSt), warm up at no load is required.

\*5 ISO mounting and shaft also available. Contact Kawasaki for further information.

\*6 SAE E through drive uses the SAE D shaft

### Table 2.1 Input Shaft Torque Rating

Shaft Type	SAE B	SAE BB	SAE C	SAE CC	SAE D/E	SAE F
Input torque lbf-ft (Nm)	126 (171)	182 (248)	378 (514)	610 (827)	1014 (1379)	1327 (1800)

Shaft surface will have finite life due to wear unless adequate lubrication is provided.

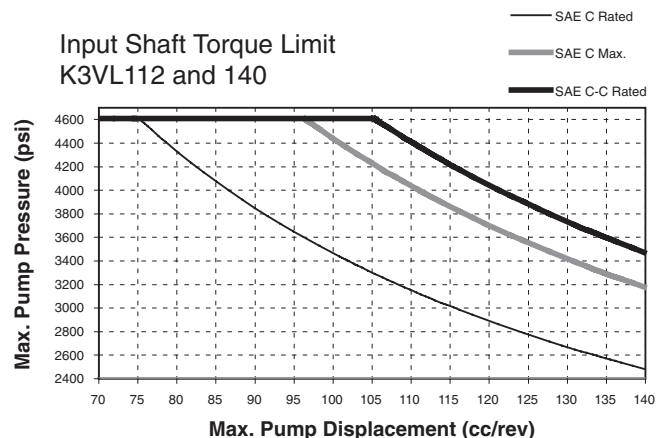
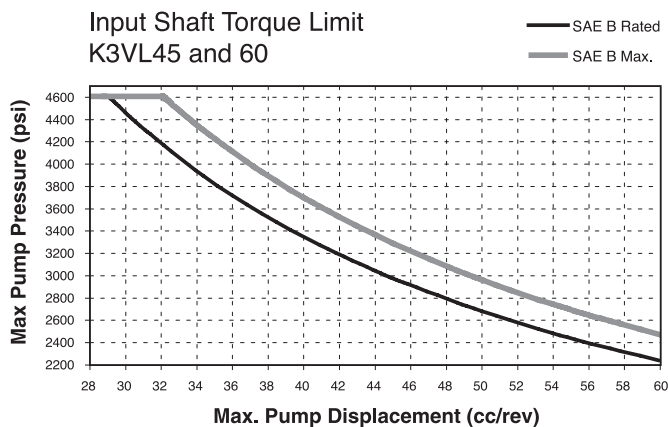

### 3.0 Model Coding

**K3VL 80 /B - 1 0 R K S - L0 ( ) (24D) ( ) /1 - H1**  
**[1] [2] [3] [4] [5] [6] [7] [8] [9] [10] [11] [12] [13] [14] [15]**

[1]	K3VL Series Variable Displacement, Axial Piston, Open Loop Pump		
[2]	Maximum Displacement	28 45 60 80 112 140 200	28 cc/rev (1.71 in <sup>3</sup> /rev) 45 cc/rev (2.75 in <sup>3</sup> /rev) 60 cc/rev (3.66 in <sup>3</sup> /rev) 80 cc/rev (4.88 in <sup>3</sup> /rev) 112 cc/rev (6.83 in <sup>3</sup> /rev) 140 cc/rev (8.54 in <sup>3</sup> /rev) 200 cc/rev (12.20 in <sup>3</sup> /rev)
[3]	Design Series	B C	Series B (45-200) Series C (K3VL28)
[4]	Hydraulic Fluid	- V W	Mineral oil (Nitrile seals except Viton shaft seal) Viton seals Water Glycol
[5]	Circuit Type	1	Open circuit
[6]	Through Drive	0 A B *1 BB C C4 *2 CC *2 CC4 D E F R N S	Without through drive (Right hand rotation only) SAE A shaft coupling and mount SAE B shaft coupling and mount SAE BB shaft coupling and SAE B mount SAE C shaft coupling and mount SAE C shaft coupling and SAE C 4 bolt mount SAE CC shaft coupling and SAE C mount SAE CC shaft coupling and SAE C 4 bolt mount SAE D shaft coupling and mount SAE D shaft coupling and SAE E mount SAE F shaft coupling and SAE E mount Rear ports (No through drive) With through drive covered and sealed; no shaft coupling included Stock model; no steel cover or shaft coupling included
[7]	Direction of Rotation	R L	Clockwise Counterclockwise (Not available as 0 through drive option)
[8]	Mounting and Shaft Type	K S M T C X W Y F	SAE mounting flange with SAE straight key shaft SAE mounting flange with SAE spline shaft ISO mounting flange with ISO straight key shaft SAE B mounting flange with SAE B spline shaft (K3VL45 and 60 only) SAE C mounting flange with SAE C spline shaft (K3VL112 and 140 only) SAE C mounting flange with SAE C straight key shaft (K3VL112 and 140 only) SAE C mounting flange with SAE C -C spline shaft (K3VL112 and 140 only) SAE C mounting flange with SAE C-C straight key shaft (K3VL112 and 140 only) SAE E mounting flange with SAE F spline shaft (K3VL200 only)
[9]	Port Options	S M	SAE 4-bolt flange ports with UNC threads SAE 4-bolt flange ports with metric threads
[10]	Control Device	L0 L1 *1 LM *1 LN *1,*3 LV *1,*4 LV2 P0 *1 PM *1 PN *1,*3 PV *1,*4 PV2	Load sense and pressure cut-off Load sense and pressure cut-off (No bleed off for load sense line) Load sense regulator with integral unloading valve (Normally open) Load sense regulator with integral unloading valve (Normally closed) Load sense regulator with integral proportional relief valve (Industrial applications) Load sense regulator with integral proportional relief valve (mobile applications) Pressure cut-off Pressure cut-off with integral unloading valve (Normally open) Pressure cut-off with integral unloading valve (Normally closed) Pressure cut-off with integral proportional relief valve (Industrial applications) Pressure cut-off with integral proportional relief valve (Mobile applications)
[11]	Regulator Modifications	*1 Blank B C D	No modifications, standard setting differential pressure springs Regulator bypass block, standard setting differential pressure springs High setting differential pressure springs Regulator bypass block, high setting differential pressure springs

[12]	Solenoid voltage for integral unloading valve (LN/PN option)	115A 230A 6D 12D 24D	115 VAC 50/60Hz 230 VAC 50/60Hz 6 VDC 12 VDC 24 VDC
[13]	Solenoid connector type	A B	Two pin Deutsch DT04-2P connector DIN Connector - ISO/DIN 43650 - Form A
[14]	Torque Limiting and Displacement Control	blank /1	Without torque limiting or displacement control With torque limiting or displacement control
[15]		** E0 QO	For torque limiting refer to horsepower setting codes below Electronic displacement control Pilot operated displacement control

\*1 Not available on K3VL28

\*2 Only available on K3VL112 and K3VL140

\*3 LV and PV options require an amplifier; See section 16 for amplifiers

\*4 LV2/PV2 available with 12VDC or 24VDC solenoid coils; See section 16 for amplifiers

Input Speed = 1150 RPM							
Motor power		K3VL Pump Frame Size					
HP	ft-lbs	45	60	80	112	140	200
5	23	S4					
6	27	S3					
6.6	30	S2					
7.2	33	S1	S4	S4			
8	36	L4	S3	S3			
9	39	L3	S2	S2			
10	45	L2	S1	S1	S6		
11	51	L1	L4	L6	S5		
13	60	M4	L3	L5	S4		
15	69	M3	L2	L4	S3	S4	
16	75	M2	L1	L3	S2	S3	
18	81	M1	M4	L2	S1	S2	
20	90	H4	M3	L1	L4	S1	
24	108	H3	M2	M4	L3	L6	
25	114	H2	M1	M3	L2	L5	
26	120	H1	H3	M2	L1	L4	S2
29	132		H2	M1	M4	L3	S1
33	150		H1	H4	M3	L2	L5
35	162			H3	M2	L1	L4
39	180			H2	M1	M3	L3
49	222			H1	H4	M2	L2
49	225				H3	M1	L1
59	270				H2	H4	M3
66	300				H1	H3	M2
73	333					H2	M1
79	360					H1	H6
87	399						H5
99	450						H4
100	456						H3
115	525						H2
122	555						H1

Input Speed = 1750 RPM							
Motor power		K3VL Pump Frame Size					
HP	ft-lbs	45	60	80	112	140	200
7.5	23	S4					
9	27	S3					
10	30	S2					
11	33	S1	S4	S4			
12	36	L4	S3	S3			
13	39	L3	S2	S2			
15	45	L2	S1	S1	S6		
17	51	L1	L4	L6	S5		
20	60	M4	L3	L5	S4		
23	69	M3	L2	L4	S3	S4	
25	75	M2	L1	L3	S2	S3	
27	81	M1	M4	L2	S1	S2	
30	90	H4	M3	L1	L4	S1	
36	108	H3	M2	M4	L3	L6	
38	114	H2	M1	M3	L2	L5	
40	120	H1	H3	M2	L1	L4	S2
44	132		H2	M1	M4	L3	S1
50	150		H1	H4	M3	L2	L5
54	162			H3	M2	L1	L4
60	180			H2	M1	M3	L3
74	222			H1	H4	M2	L2
75	225				H3	M1	L1
90	270				H2	H4	M3
100	300				H1	H3	M2
111	333					H2	M1
120	360					H1	H6
133	399						H5
150	450						H4
152	456						H3
175	525						H2
185	555						H1

- S Spring type: Ultra-low spring force
- L Spring type: Low spring force
- M Spring type: Medium spring force
- H Spring type: High spring force
- 1-6 Adjustment setting

The shaded areas of the chart indicate torque limiter settings which may not allow the pump to achieve full flow or pressure. Contact Kawasaki for application assistance.

## 4.0 Functional Description of Regulators

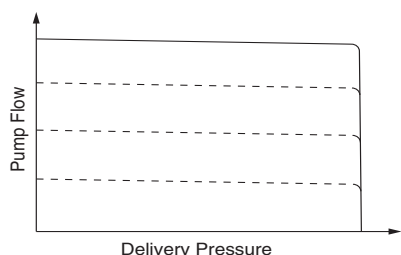
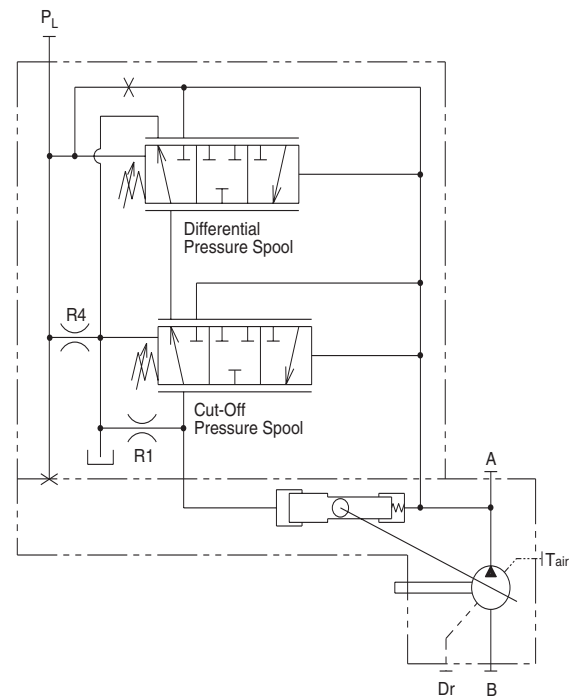
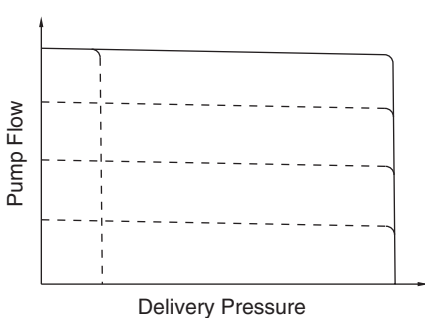
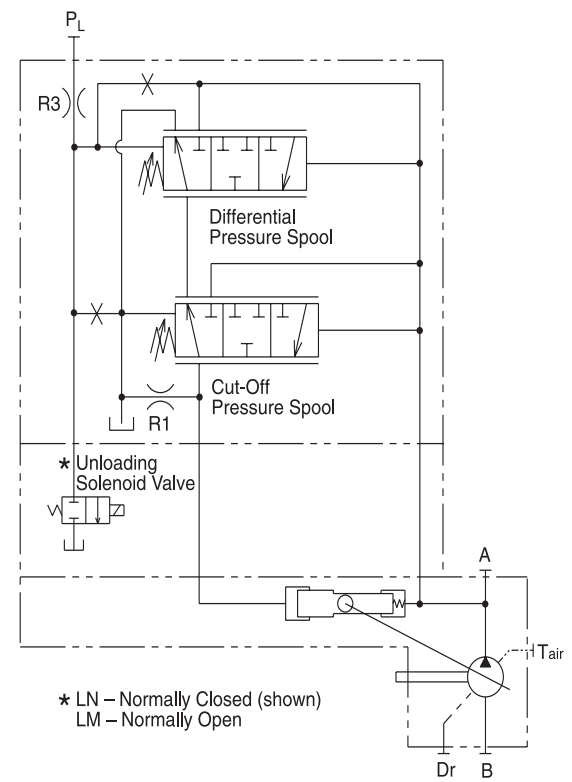
Regulator code	Hydraulic Circuit
<p><b>LO/L1 Load Sense and Pressure Cut-off</b></p> <p>Description: The load sense regulator controls the pump displacement to best match the flow and pressure requirements of the load.</p> <p>The pump delivery pressure (<math>D_p</math>) is the sum of the load pressure (<math>L_s</math>), and the differential pressure (<math>\Delta P</math>) setting. <math>L_s + \Delta P = D_p</math></p> <p>When the pump discharge pressure reaches the preset value of the cut-off spool, the pump destrokes to limit the outlet pressure to that setting. When the system requires no flow or pressure, the pump returns to an energy saving low pressure standby condition.</p> <p><b>Differential Pressure:</b>            Standard Setting - 218 psi (15 bar)            Standard Differential Pressure Adjustment Range            K3VL45-200: 145 psi (10 bar) ~ 300 psi (21 bar)            High Differential Pressure Adjustment Range            K3VL45-80: 145 psi (10 bar) ~ 652 psi (45 bar)            K3VL80-200: 145 psi (10 bar) ~ 870 psi (60 bar)</p> <p><b>Cut-off Pressure:</b>            Standard Setting - 4600 psi (320 bar)            Adjustment range - 300 psi (21bar) ~ 4600 psi (320 bar)</p> <p><b>L1 Option:</b> With the L1 option, the bleed-off orifice (R4) is plugged. When this option is applied, there must be another bleed-off orifice in the external valving to prevent trapped pressure.</p> <p><b>Bypass Block Option:</b> The bypass block is a manifold which contains a check valve and is sandwiched under load sense regulator. The bypass block allows the two regulator spools to operate in parallel, enabling faster off stroke times. The performance improvement varies according to operating pressure and pump displacement.</p> 	
<p><b>LN or LM Loadsense and Pressure Cut-off with Integrated Unloading Valve*</b></p> <p>Description: An integrated unloading valve is sandwiched between the load sense regulator and the pump which allows the pump to operate in a low pressure standby condition.</p> <p>Standby Pressure: The standby pressure is approximately 200 psi (14 bar) at the minimum differential pressure setting.</p> <p>* Can also be used with the torque limiting and proportional displacement control regulators</p> 	 <p>* LN – Normally Closed (shown)            LM – Normally Open</p>

**Warning:** A safety relief valve should be installed in the hydraulic circuit at the pump outlet.

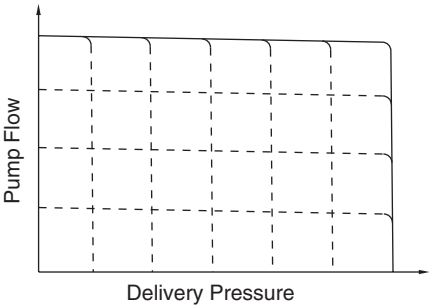
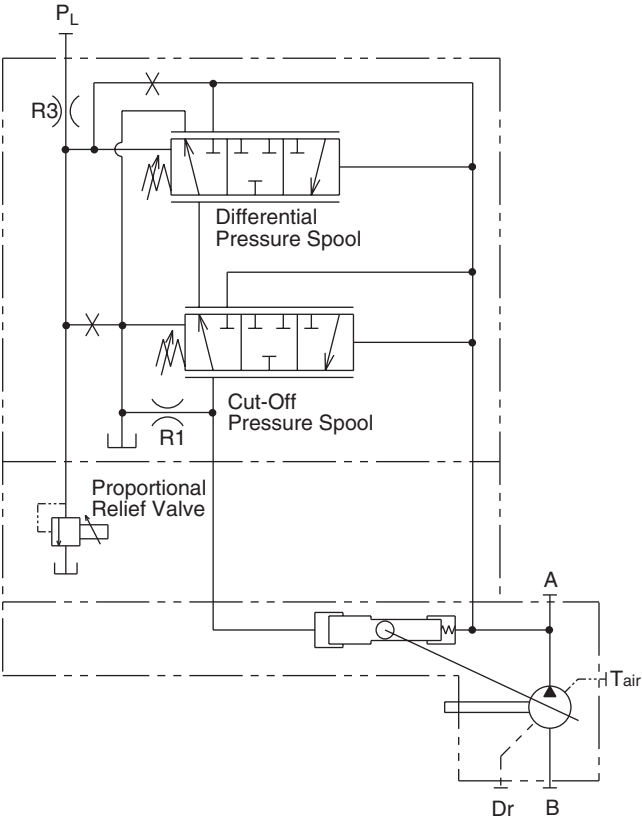
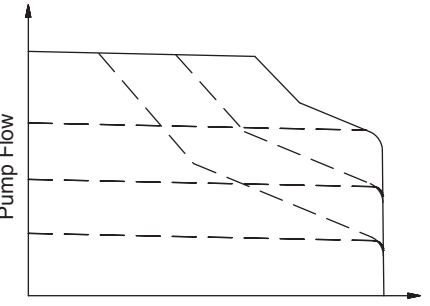
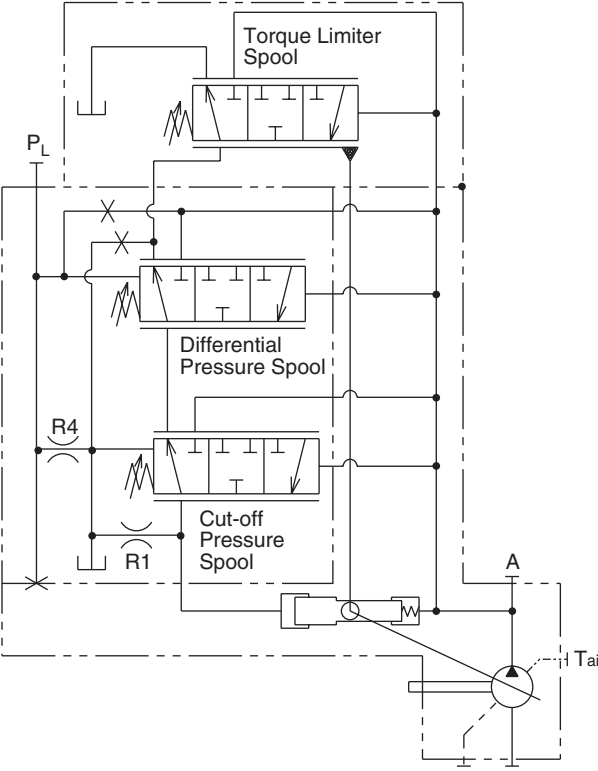
Regulator code	Hydraulic Circuit
<p><b>LV or LV2 Load Sense and Pressure Cut-off with Integrated Proportional Relief Valve*</b></p> <p><b>Description:</b> An integrated proportional relief valve is sandwiched between the load sense regulator and pump to control the maximum operating pressure by varying an electrical signal to the valve.</p> <p>The LV control is designed for industrial applications operating on 24vdc control power.</p> <p>The LV2 control is designed for mobile applications operating on 12vdc or 24vdc control power.</p> <p><b>Standby Pressure:</b> The standby pressure is approximately 200 psi (14 bar) at the minimum differential pressure setting.</p> <p><b>Amplifier:</b> A separate amplifier is required for either control option. See section 16 for available amplifiers.</p> <p>* Can also be used with the torque limiting and proportional displacement control regulators</p> 	
<p><b>L0/1-** Load Sensing and Pressure Cut-off with Torque Limiting</b></p> <p><b>Description:</b> The L0/L1 control functions as previously noted. The torque limiter regulator controls the pump displacement to best match the power available from the prime mover.</p> <p>The torque limiter regulator monitors delivery pressure and the swashplate angle and adjusts the pump displacement to limit input torque to a preset value.</p> <p>The preset torque limit value (T - ft-lbs) may be calculated using prime mover drive speed (N - rpm) and power value. (HP - horsepower) <math>T = Hp \times 5252/N</math></p> <p>Please reference the torque limiting code chart on page 3.</p> 	

**Warning:** A safety relief valve should be installed in the hydraulic circuit at the pump outlet.

## 4.0 Functional Description of Regulators (Continued)

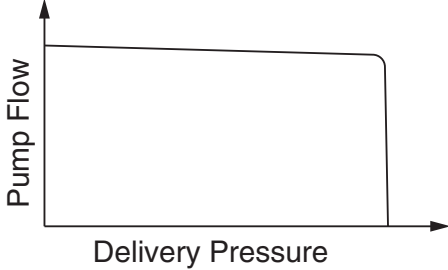
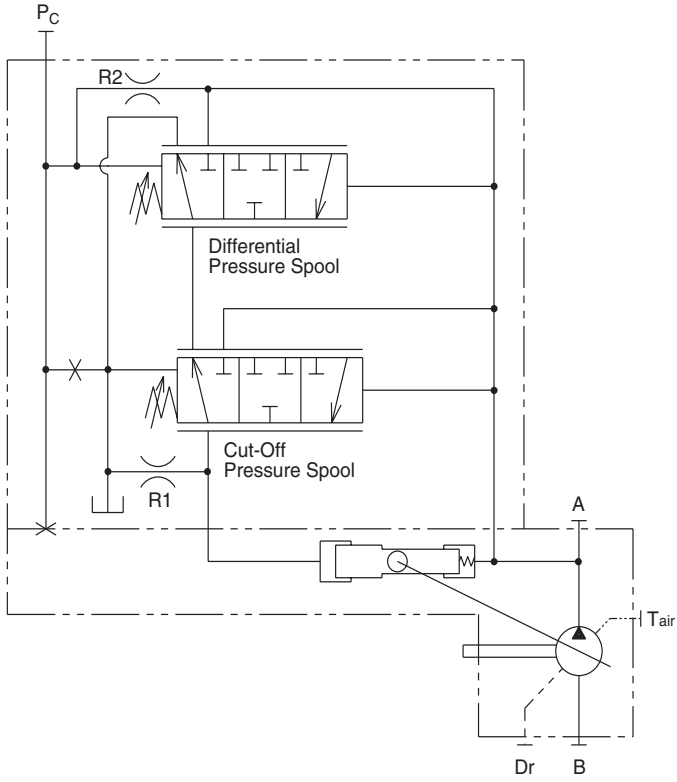
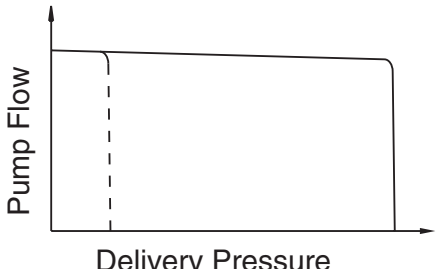
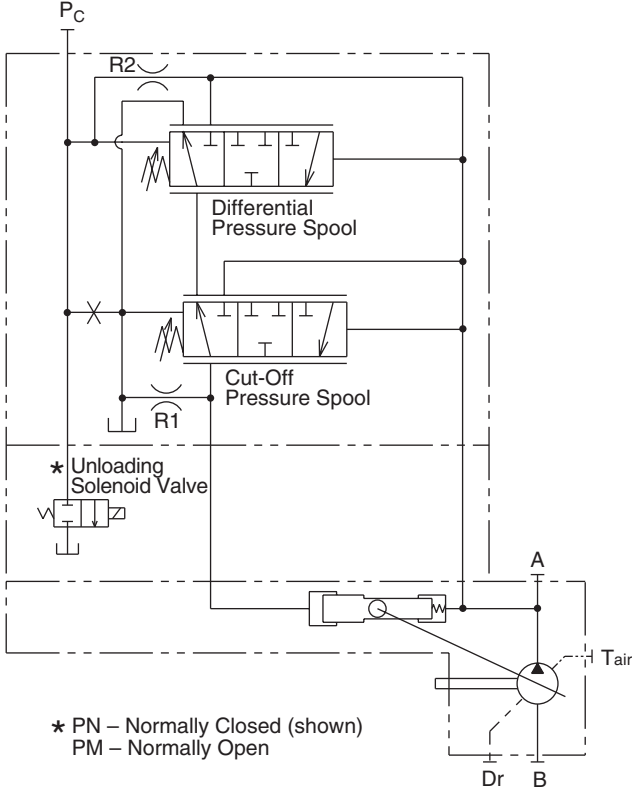
Regulator code	Hydraulic Circuit
<p><b>P0 Pressure Cut-off</b></p> <p><b>Description:</b> The Pressure Cut-off regulator monitors delivery pressure and destrokes the pump once the pressure reaches the cut-off pressure setting. When the delivery pressure drops below the cut-off setting, the pump will return to maximum displacement.</p> <p><b>Differential Pressure:</b>            Standard Setting - 218 psi (15 bar)            Standard Differential Pressure Adjustment Range            K3VL45-200: 145 psi (10 bar) ~ 300 psi (21 bar)            High Differential Pressure Adjustment Range            K3VL45-80: 145 psi (10 bar) ~ 652 psi (45 bar)            K3VL80-200: 145 psi (10 bar) ~ 870 psi (60 bar)</p> <p><b>Cut-off Pressure:</b>            Standard Setting - 4600 psi (320 bar)            Adjustment Range - 300 psi (21 bar) ~ 4600 psi (320 bar)</p> <p><b>Remote Control:</b> The pump can be remotely controlled by connecting a relief valve to the Pc port of the regulator. The flow rate from the Pc port will be ~.4 gpm (1.5 lpm). The pump can also be unloaded to operate at a low pressure standby condition by using a solenoid valve.</p> 	
<p><b>PN or PM Pressure Cut-off with Integrated Unloading Valve*</b></p> <p><b>Description:</b> An integrated unloading valve is sandwiched between the pressure cut-off regulator and the pump which allows the pump to operate in a low pressure standby condition.</p> <p><b>Standby Pressure:</b> The standby pressure is approximately 200 psi (14 bar) at the minimum differential pressure setting.</p> <p>* Can also be used with the torque limiting and proportional displacement control regulators</p> 	 <p>* PN – Normally Closed (shown)        PM – Normally Open</p>

**Warning:** A safety relief valve should be installed in the hydraulic circuit at the pump outlet.

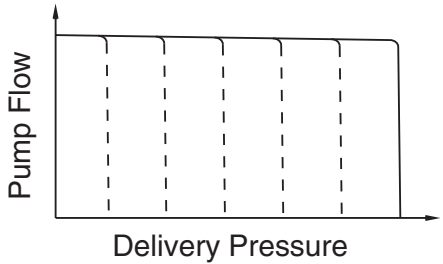
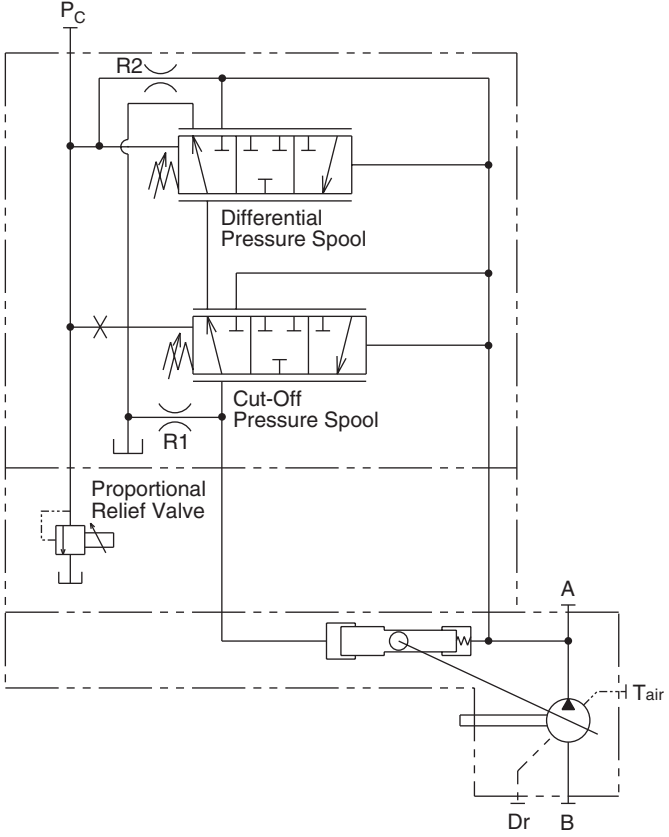
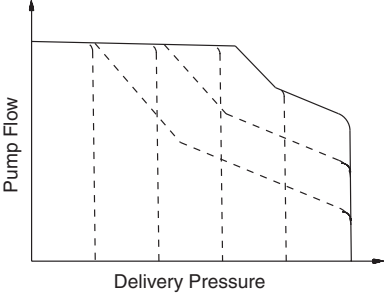
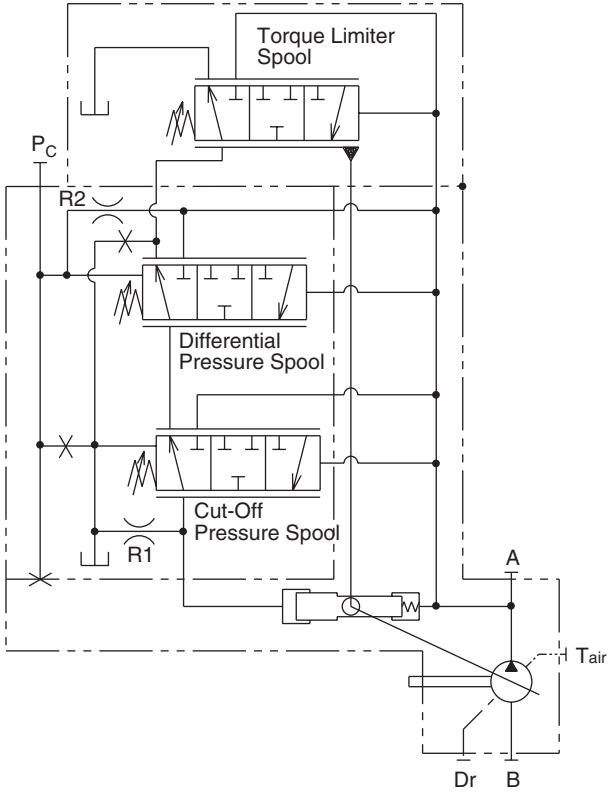
Regulator code	Hydraulic Circuit
<p><b>PV or PV2 Pressure Cut-off with Integrated Proportional Relief Valve*</b></p> <p><b>Description:</b> An integrated proportional relief valve is sandwiched between the pressure cut-off regulator and pump to control the maximum operating pressure by varying an electric signal to the valve.</p> <p>The PV control is designed for industrial applications operating on 24vdc control power.</p> <p>The PV2 control is designed for mobile applications operating on 12vdc or 24vdc control power.</p> <p><b>Standby Pressure:</b> The standby pressure is approximately 200 psi (14 bar) at the minimum differential pressure setting.</p> <p><b>Amplifier:</b> Separate amplifier is required for either control option. See Section 16 for available amplifiers.</p> <p>* Can also be used with the torque limiting and proportional displacement control regulators</p> 	
<p><b>P0/1-** Pressure Cut-off with Torque Limiting</b></p> <p><b>Description:</b> The P0 control functions as previously noted. The torque limiter regulator controls the pump displacement to best match the power available from the prime mover.</p> <p>The torque limiter regulator monitors delivery pressure and the swashplate angle and adjusts the pump displacement to limit input torque to a preset value.</p> <p>The preset torque limit value (T - ft-lbs) may be calculated using prime mover drive speed (N - rpm) and power value. (HP - horsepower) <math>T = Hp \times 5252/N</math></p> <p>Please reference the torque limiting code chart on page 3.</p> <p><b>Remote Control:</b> The pump can be remotely controlled by connecting a relief valve to the Pc port of the regulator. The flow rate from the Pc port will be ~.4 gpm (1.5 lpm).</p> <p>The pump can also be unloaded to operate at a low pressure standby condition by using a solenoid valve.</p> 	

**Warning:** A safety relief valve should be installed in the hydraulic circuit at the pump outlet.

## 4.0 Functional Description of Regulators (Continued)

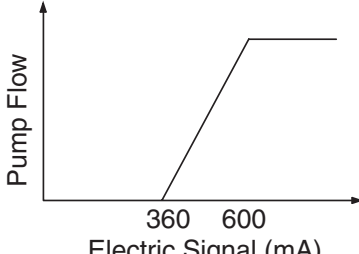
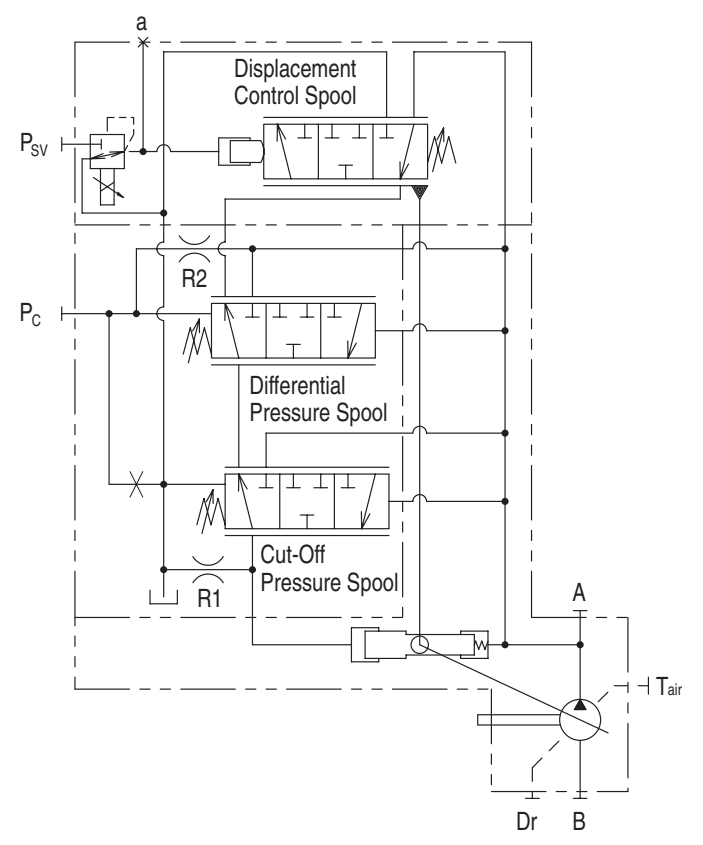
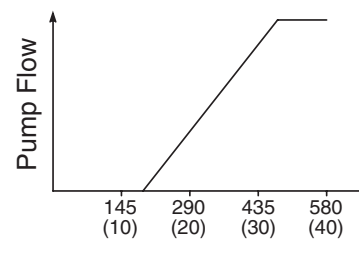
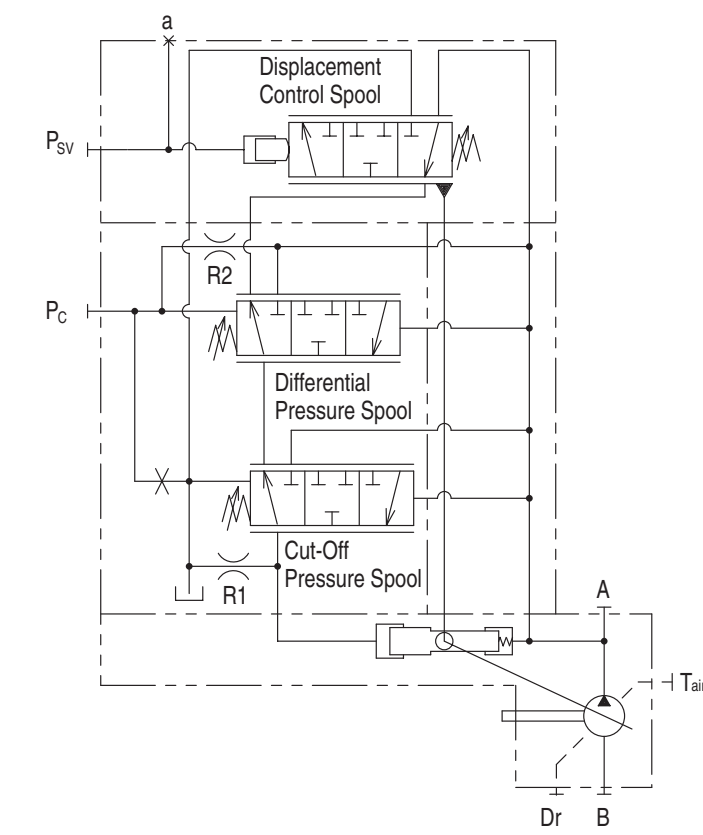
Regulator code	Hydraulic Circuit
<p><b>P0/1-E0 Electronic Proportional Displacement Control with Pressure Cut-off</b></p> <p><b>Description:</b> The P0 control functions as previously noted. A proportional pressure reducing valve (PPRV) is added to the regulator so the pump flow can be infinitely controlled within the displacement range of the pump. An increase in electric signal to the PPRV will result in an increase in flow. A pilot pressure of 580 psi must be supplied to the PSV port.</p> <p><b>Note:</b> The pump outlet pressure must be greater than 100 psi for proper regulator operation.</p> <p><b>Amplifier:</b> A pulse width modulated (PWM) amplifier is required to operate the E0 control. The recommended dither frequency is 50-200Hz.</p> <p>See section 16 for amplifiers.</p> <p><b>Coil specifications:</b></p> <p><b>Rated current: 700 mA</b></p> <p><b>Recommended dither frequency: 50-200Hz</b></p> <p><b>Coil resistance: 17.5Ω at 20° C</b></p> <p><b>Connector type: Nihon AMP Econoseal J series, Mark I</b></p> 	
<p><b>P0/1-Q0 Hydraulic Pilot Displacement Control with Pressure Cut-off</b></p> <p><b>Description:</b> P0 control functions as previously noted. By applying a varying hydraulic pilot pressure to the Psv port of the displacement controller, the pump flow can be infinitely controlled within the displacement range of the pump. An increase in the hydraulic pilot signal results in an increase of output flow. Maximum output flow is achieved at 480 psi.</p> <p><b>Remote control:</b> By connecting the Pc port to a remote pressure control, variable pump pressure control (or unloading) can be achieved.</p> 	

## 5.0 Performance Curves — K3VL28

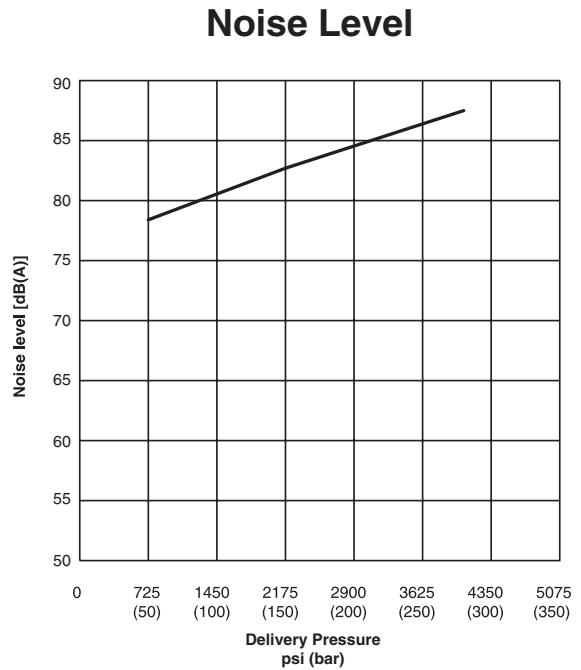
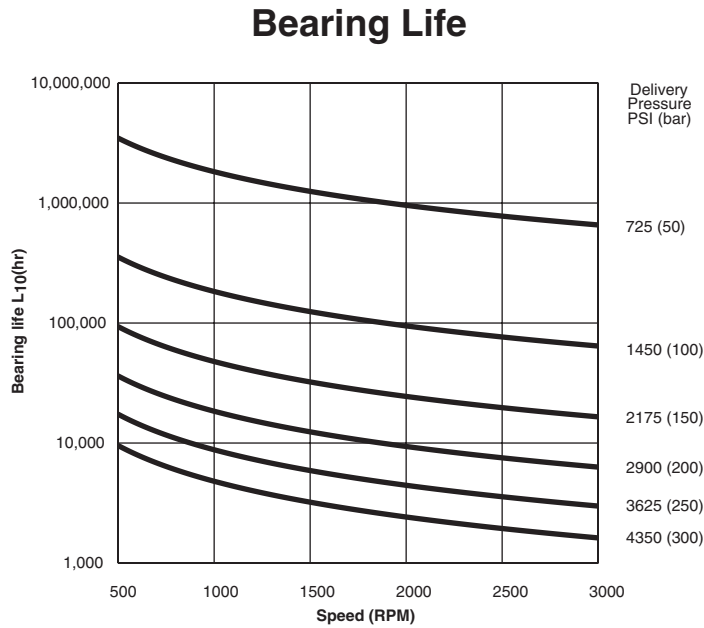
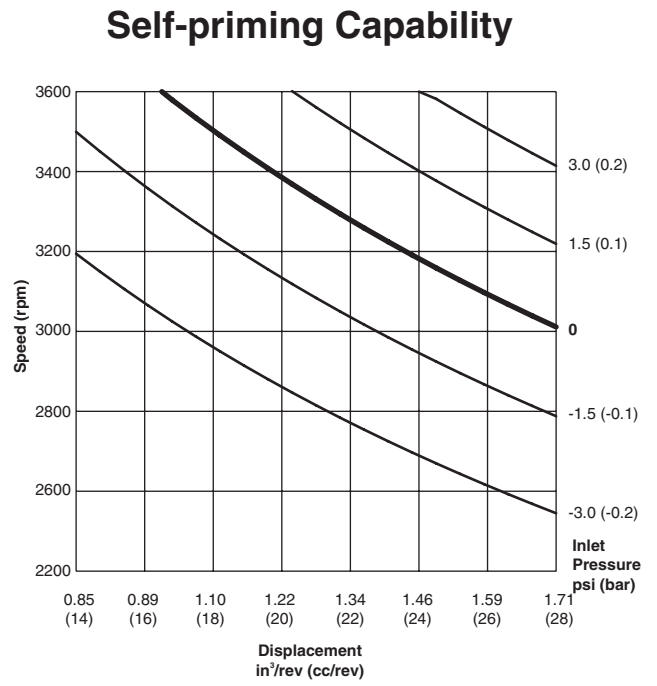
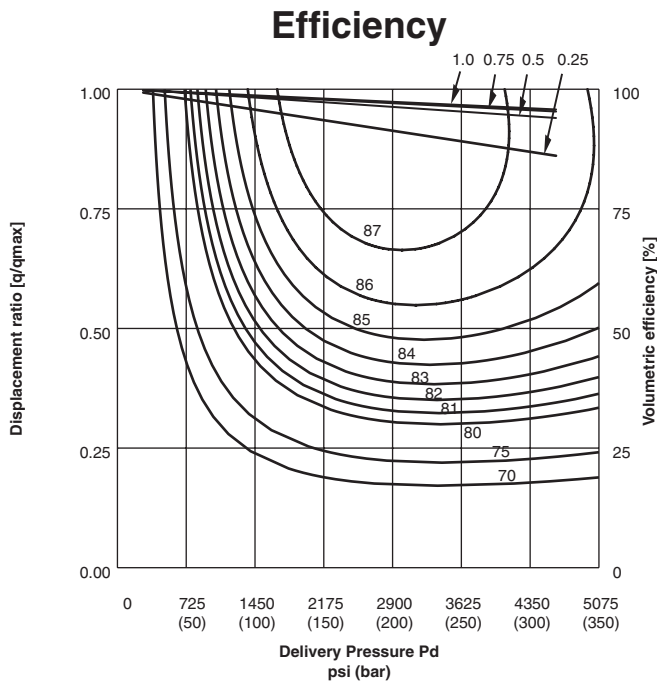

#### Performance Notes:

1. All curves are based on an input speed of 1800 rpm, ISOVG46 hydraulic oil, 122°F (50°C) oil temperature, and 0 psi (0 bar) inlet condition, unless otherwise noted.
2.  $L_{10}$  bearing life is defined as the period of time for 10% of an identical group of bearings operated under the same conditions to begin to fail as a result of rolling fatigue. Bearing life is further reduced by elevated temperatures, contamination, shaft radial loads, and lubricant breakdown. Consult Kawasaki for detailed bearing life analysis.
3. Noise levels are measured in a semi-anechoic chamber in a manner similar to NFPA 13.9.70.12 and DIN 43635
4. For application requirements not covered by the performance curves above, consult Kawasaki.

## 5.0 Performance Curves — K3VL45

### Efficiency

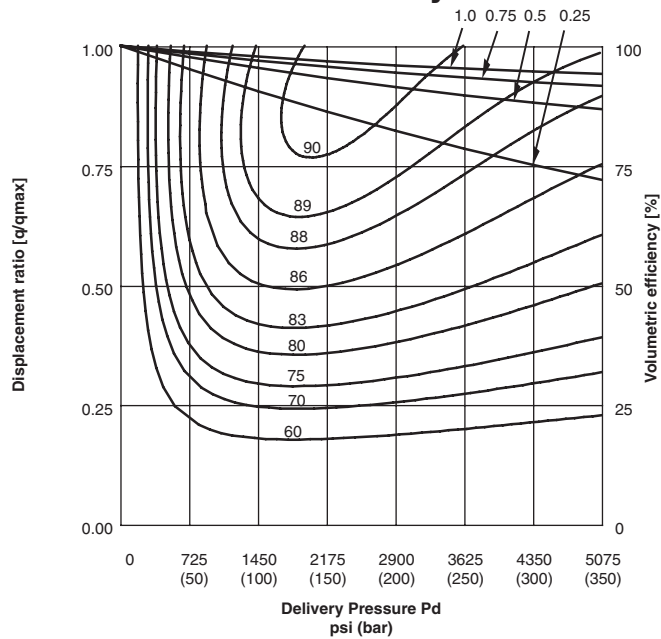

### Self-priming Capability

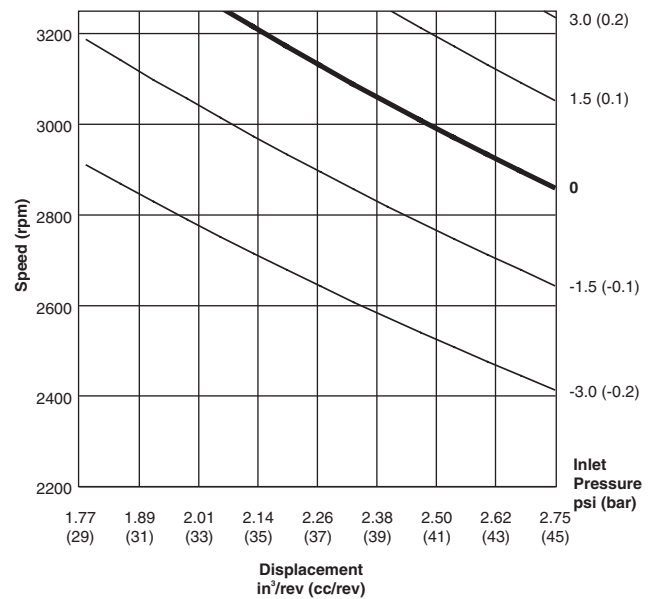

### Bearing Life

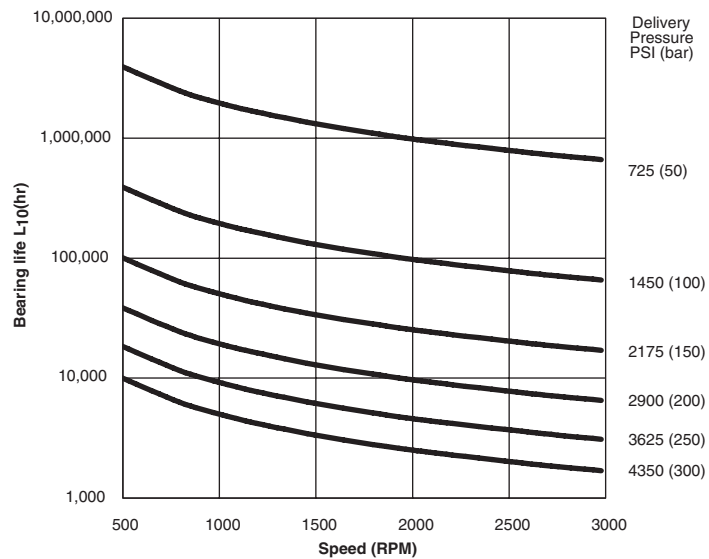

### Noise Level

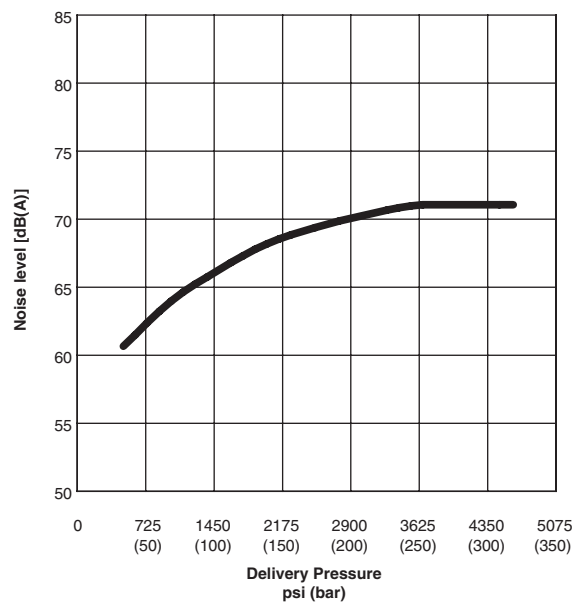

#### Performance Notes:

- All curves are based on an input speed of 1800 rpm, ISOVG46 hydraulic oil, 122°F (50°C) oil temperature, and 0 psi (0 bar) inlet condition, unless otherwise noted.
- $L_{10}$  bearing life is defined as the period of time for 10% of an identical group of bearings operated under the same conditions to begin to fail as a result of rolling fatigue. Bearing life is further reduced by elevated temperatures, contamination, shaft radial loads, and lubricant breakdown. Consult Kawasaki for detailed bearing life analysis.
- Noise levels are measured in a semi-anechoic chamber in a manner similar to NFPA 13.9.70.12 and DIN 43635
- For application requirements not covered by the performance curves above, consult Kawasaki.

# 5.0 Performance Curves — K3VL60

### Efficiency

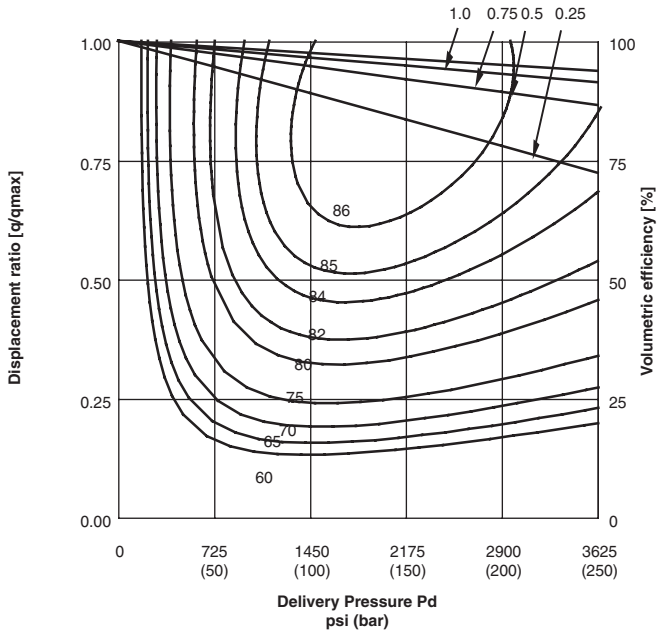

### Self-priming Capability

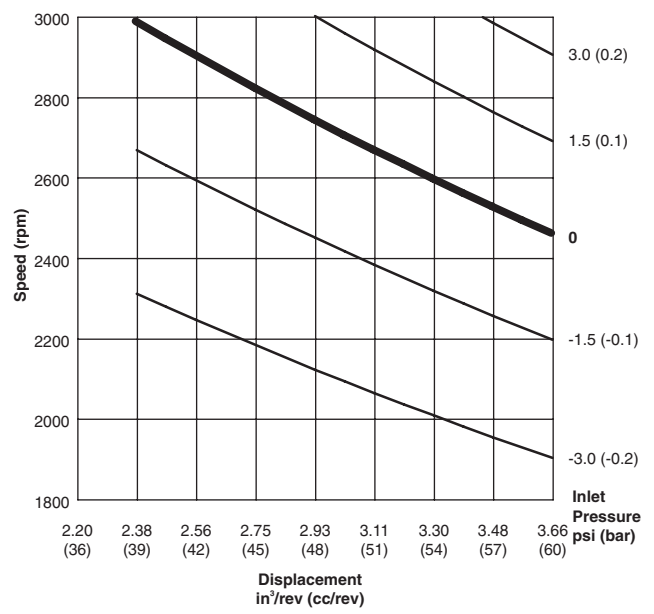

### Bearing Life

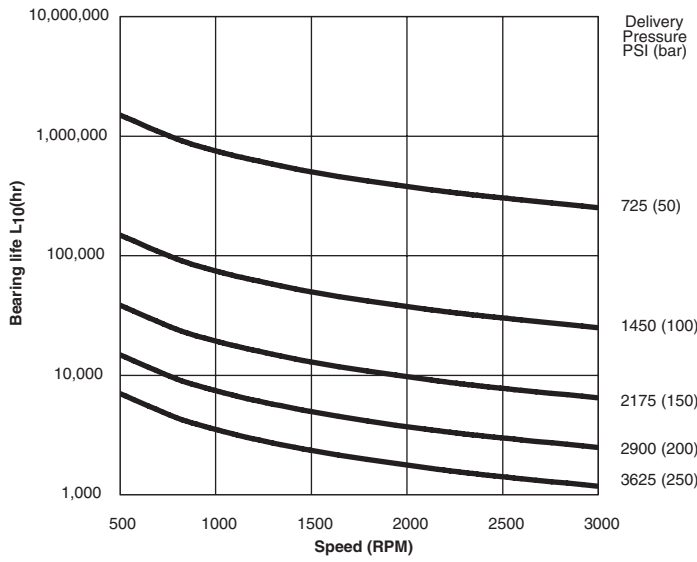

### Noise Level

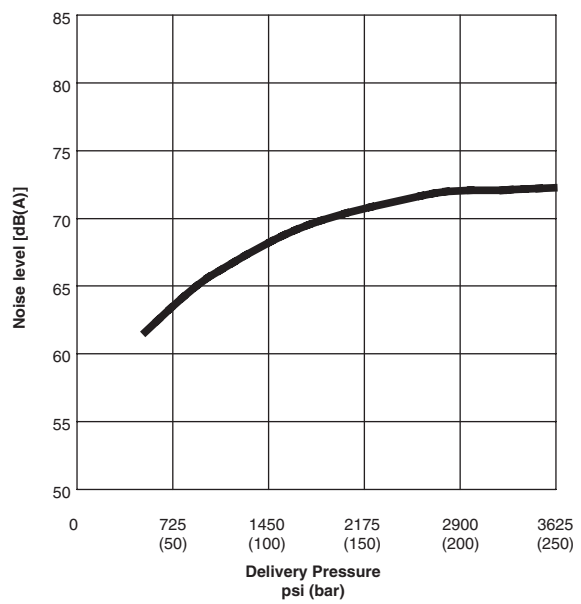

#### Performance Notes:

1. All curves are based on an input speed of 1800 rpm, ISOVG46 hydraulic oil, 122°F (50°C) oil temperature, and 0 psi (0 bar) inlet condition, unless otherwise noted.
2. L<sub>10</sub> bearing life is defined as the period of time for 10% of an identical group of bearings operated under the same conditions to begin to fail as a result of rolling fatigue. Bearing life is further reduced by elevated temperatures, contamination, shaft radial loads, and lubricant breakdown. Consult Kawasaki for detailed bearing life analysis.
3. Noise levels are measured in a semi-anechoic chamber in a manner similar to NFPA 13.9.70.12 and DIN 43635
4. For application requirements not covered by the performance curves above, consult Kawasaki.

## 5.0 Performance Curves — K3VL80

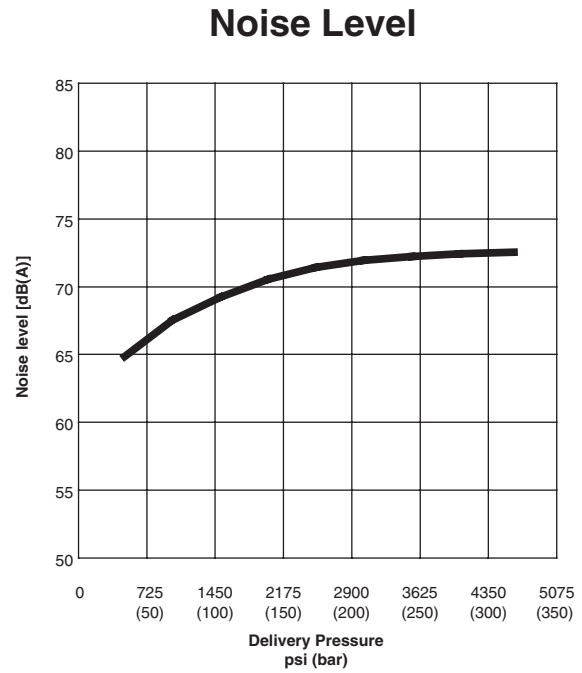
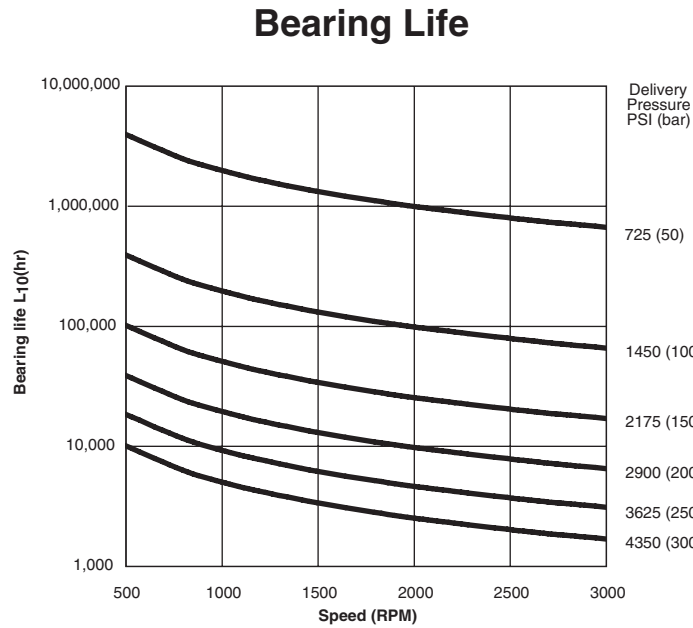
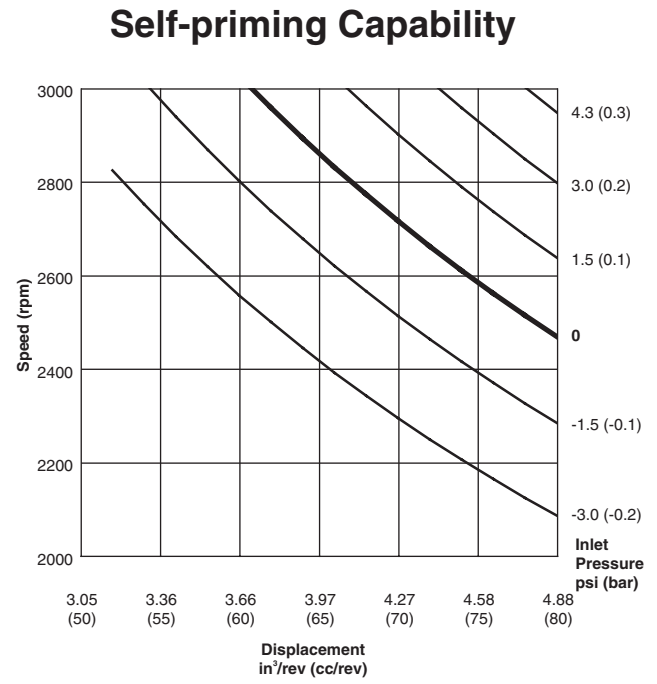
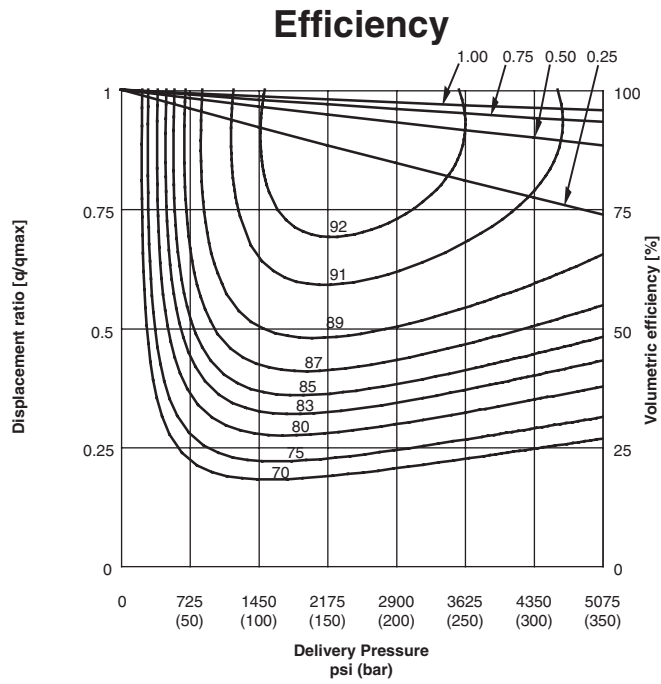

#### Performance Notes:

1. All curves are based on an input speed of 1800 rpm, ISOVG46 hydraulic oil, 122°F (50°C) oil temperature, and 0 psi (0 bar) inlet condition, unless otherwise noted.
2.  $L_{10}$  bearing life is defined as the period of time for 10% of an identical group of bearings operated under the same conditions to begin to fail as a result of rolling fatigue. Bearing life is further reduced by elevated temperatures, contamination, shaft radial loads, and lubricant breakdown. Consult Kawasaki for detailed bearing life analysis.
3. Noise levels are measured in a semi-anechoic chamber in a manner similar to NFPA 13.9.70.12 and DIN 43635
4. For application requirements not covered by the performance curves above, consult Kawasaki.

# 5.0 Performance Curves — K3VL112

### Efficiency

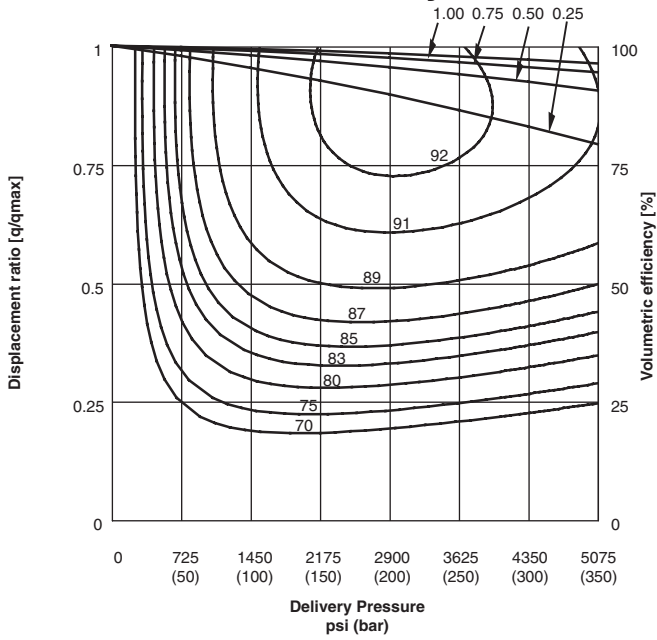

### Self-priming Capability

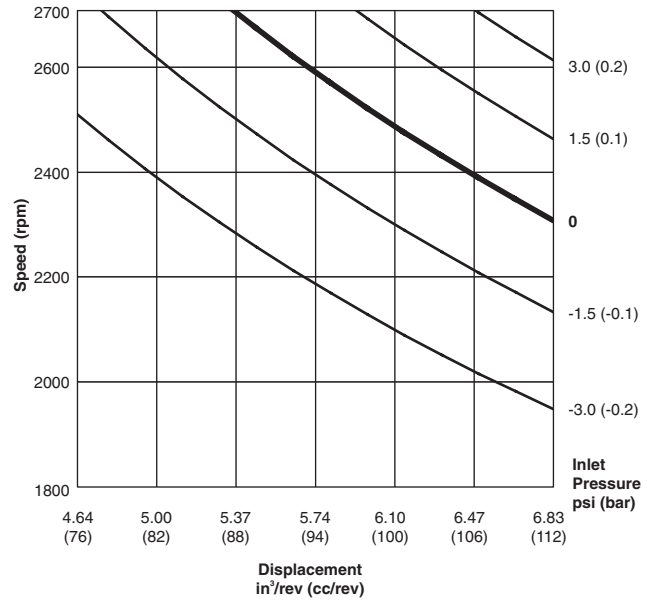

### Bearing Life

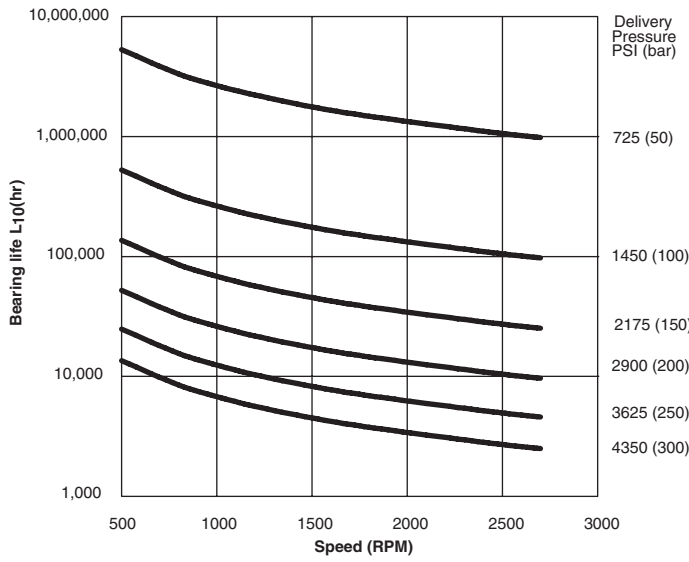

### Noise Level

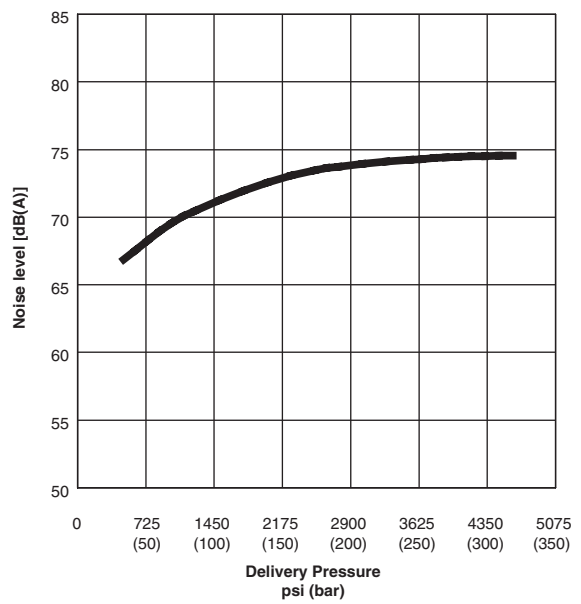

#### Performance Notes:

1. All curves are based on an input speed of 1800 rpm, ISOVG46 hydraulic oil, 122°F (50°C) oil temperature, and 0 psi (0 bar) inlet condition, unless otherwise noted.
2.  $L_{10}$  bearing life is defined as the period of time for 10% of an identical group of bearings operated under the same conditions to begin to fail as a result of rolling fatigue. Bearing life is further reduced by elevated temperatures, contamination, shaft radial loads, and lubricant breakdown. Consult Kawasaki for detailed bearing life analysis.
3. Noise levels are measured in a semi-anechoic chamber in a manner similar to NFPA 13.9.70.12 and DIN 43635
4. For application requirements not covered by the performance curves above, consult Kawasaki.

## 5.0 Performance Curves — K3VL140

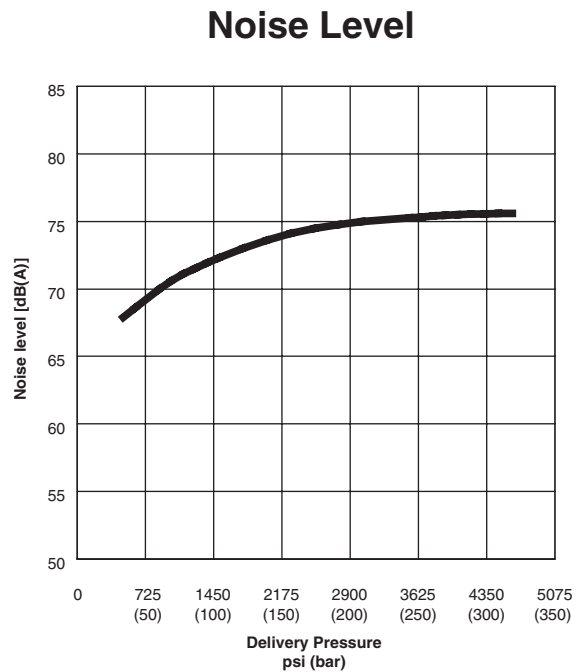
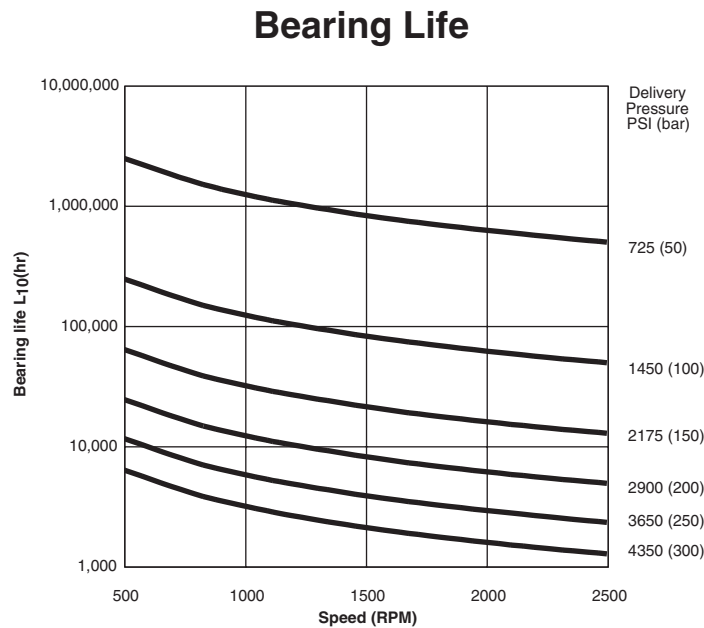
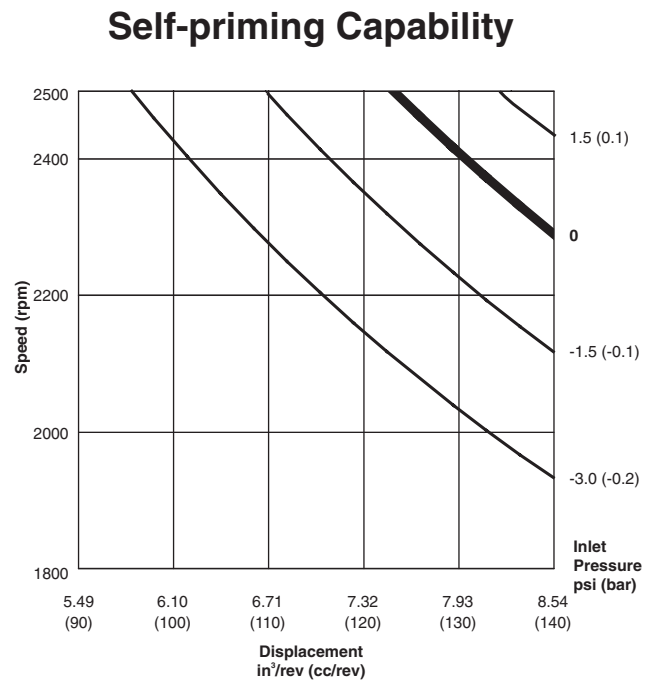
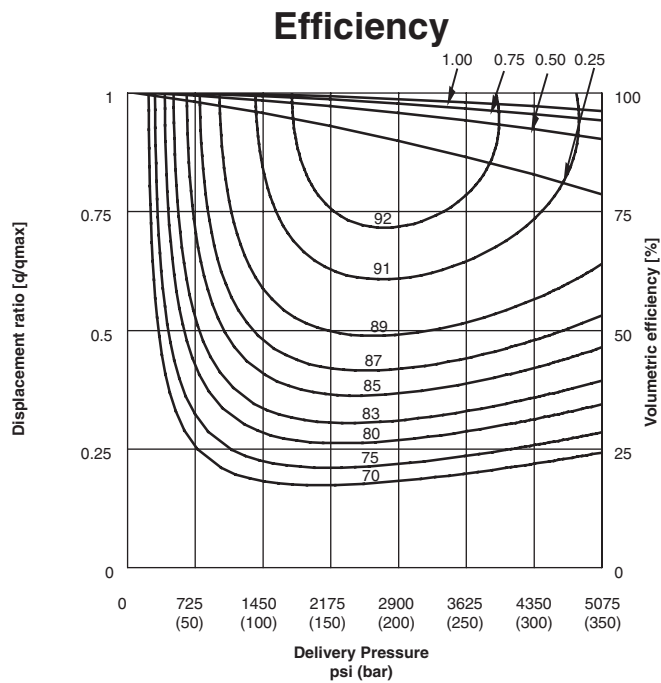

#### Performance Notes:

1. All curves are based on an input speed of 1800 rpm, ISOVG46 hydraulic oil, 122°F (50°C) oil temperature, and 0 psi (0 bar) inlet condition, unless otherwise noted.
2. L<sub>10</sub> bearing life is defined as the period of time for 10% of an identical group of bearings operated under the same conditions to begin to fail as a result of rolling fatigue. Bearing life is further reduced by elevated temperatures, contamination, shaft radial loads, and lubricant breakdown. Consult Kawasaki for detailed bearing life analysis.
3. Noise levels are measured in a semi-anechoic chamber in a manner similar to NFPA 13.9.70.12 and DIN 43635
4. For application requirements not covered by the performance curves above, consult Kawasaki.

## 5.0 Performance Curves — K3VL200

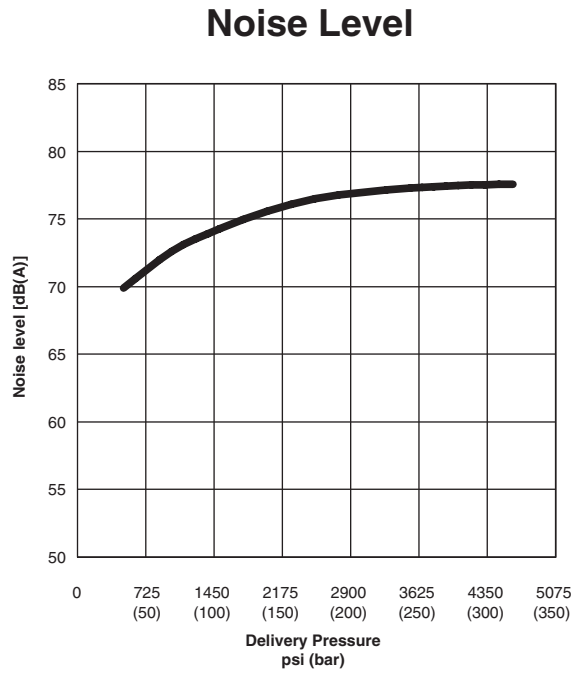
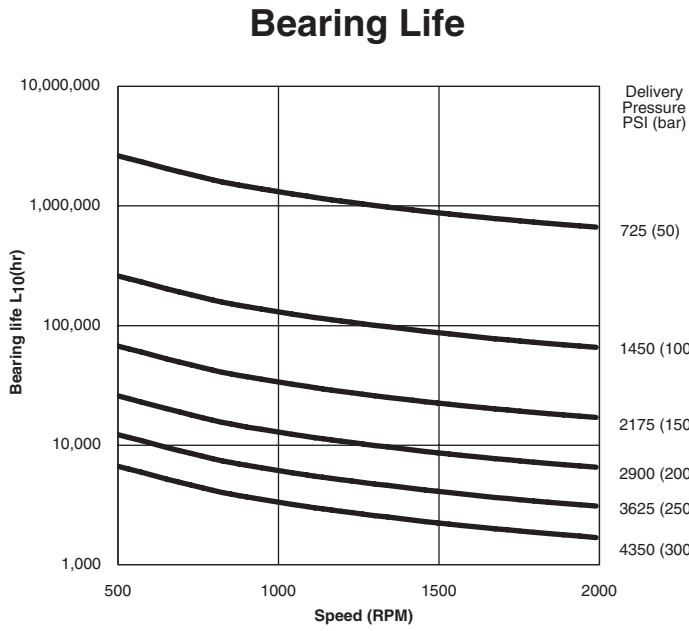
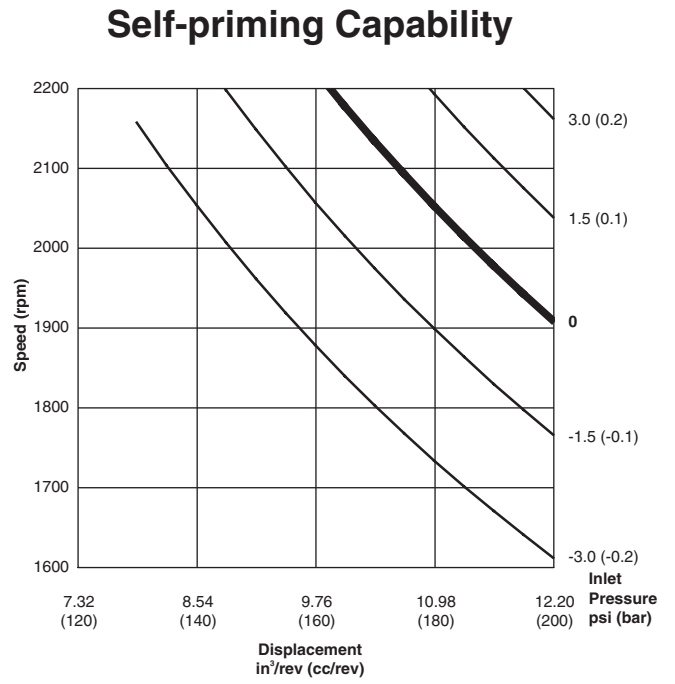
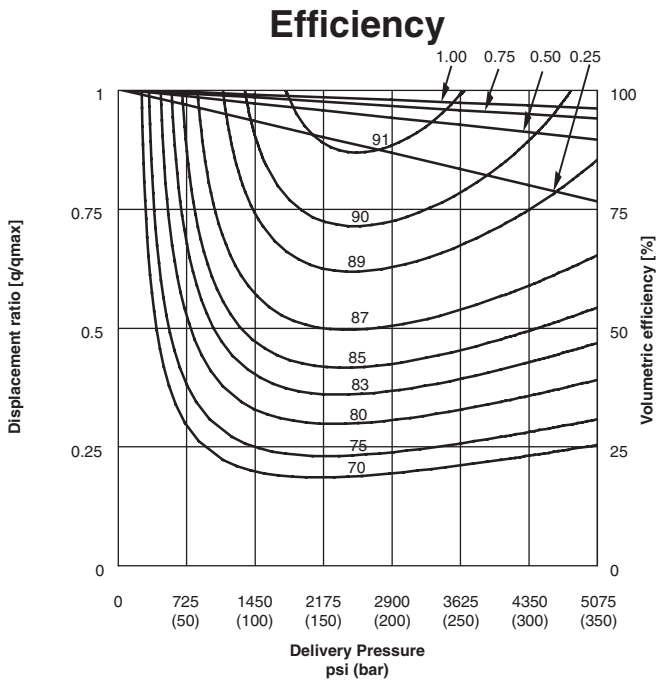

#### Performance Notes:

- All curves are based on an input speed of 1800 rpm, ISOVG46 hydraulic oil, 122°F (50°C) oil temperature, and 0 psi (0 bar) inlet condition, unless otherwise noted.
- $L_{10}$  bearing life is defined as the period of time for 10% of an identical group of bearings operated under the same conditions to begin to fail as a result of rolling fatigue. Bearing life is further reduced by elevated temperatures, contamination, shaft radial loads, and lubricant breakdown. Consult Kawasaki for detailed bearing life analysis.
- Noise levels are measured in a semi-anechoic chamber in a manner similar to NFPA 13.9.70.12 and DIN 43635
- For application requirements not covered by the performance curves above, consult Kawasaki.

## 6.0 Mounting Precautions

### Case Drain Recommendations

The pump should be mounted with the drain piping initially rising above the highest point of the pump before continuing to the tank as shown in the second illustration below. This precaution ensures that the case will remain full. Do not connect the drain line to the suction line. The uppermost drain port should be used and the drain piping should be equal to or larger in size than the drain port to minimize pressure in the pump case. The pump case pressure should never exceed 15 psi (1 bar) nominal or 60 psi (3 bar) peak, as shown in the illustration below.

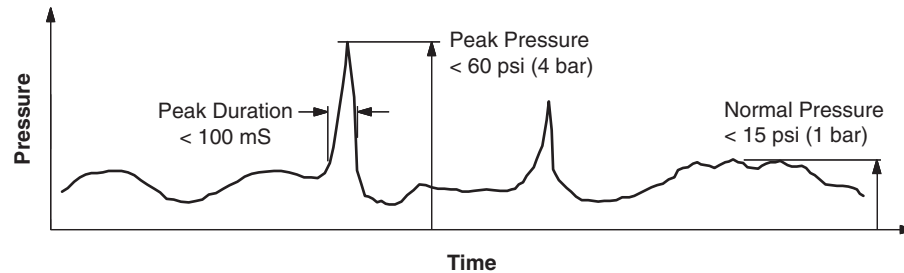

### Mounting Pump Above Tank

If the pump is to be mounted above the tank, the case drain line must initially rise above the level of the pump before continuing to the tank as shown in the illustration below. It is possible for oil in the pump case to bleed off to tank, if this precaution is not observed. The maximum height that the center of the pump inlet can be mounted above the oil level is 3.3 feet (1.0 meter). If the pump is mounted upside down, the inlet line must also rise above the level of the pump before continuing to the tank.

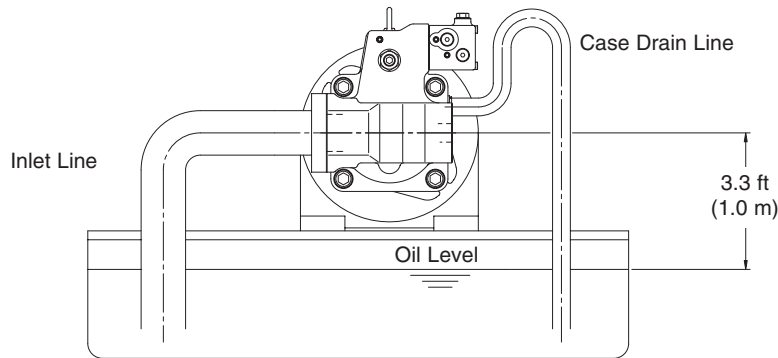

### Mounting Pump Vertically

For applications requiring vertical installation (shaft up) remove the plug from the air bleed port ( $T_{air}$ ). The oil level should be higher than the pump mounting flange as shown in illustration [a] below. If the oil level in the tank is lower than the pump mounting flange, forced lubrication is required through the air bleed port [0.25 ~ 0.50 GPM (1 ~ 2 l/min)].

When installing the pump in the tank and submerged in the oil, open the drain port (Dr) and air bleed port ( $T_{air}$ ) to provide adequate lubrication to the internal components. When installing the pump outside the tank, run piping for the drain and air bleed ports to tank as shown in illustration [c]. If the drain or air bleed piping rise above the level of oil, as in illustration [b], fill the lines with oil before operation.

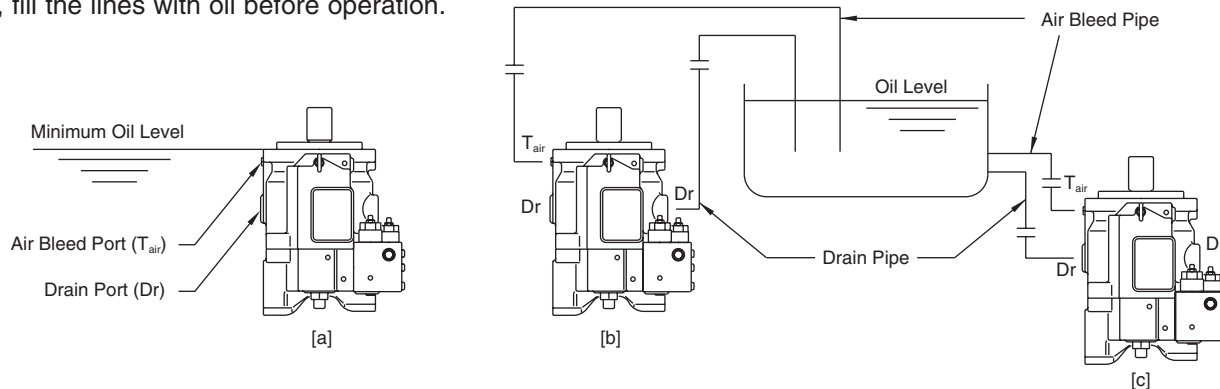

## 7.0 Filtration

For satisfactory pump service life, the oil should be continuously filtered to a cleanliness level of 20/18/15 ISO/DIS 4406 (NAS Class 9). As a minimum precaution, a 10 $\mu$  nominal filter should be installed in the return line and an 80~150 mesh strainer installed in the suction line.

## 8.0 Hydraulic Fluid Requirements

Use a high quality, anti-wear, mineral based hydraulic fluid when the pressure exceeds 3000 psi (207 bar). Oil viscosity must remain between 55 and 930 SUS (10 and 200 cSt) for normal operation.

In applications where alternate fluids are required (biodegradable fluids, water glycol, phosphate ester, etc.), please consult Kawasaki for application assistance. The seals and ratings may need to be changed to ensure compatibility and reasonable life.

Fire Resistant Fluids	Mineral Oil Anti-wear type	Water Glycol	Polyolester
Maximum Pressure - psi (bar)	4600 (320)	3000 (210)	4600 (320)
Recommended Temperature Range deg f (c)	68 -140 (20-60)	50-122 (10-50)	68 -140 (20-60)
Life expectancy compared to mineral oil	100%	20%-80%	50%-100%

## 9.0 Initial Start-up

1. Make sure the pump case is filled with clean, filtered fluid identical to that used in the rest of the system. The pump case must be full at all times to ensure proper lubrication of internal components.
2. Verify that piping is completed and any inlet valves are open to prevent cavitation or aeration of the pump.
3. Confirm that the direction of rotation of the prime mover matches the pump installed.
4. Jog start the prime mover with the pump unloaded and operate until the air is bled from the system.
5. Check the pump for external leakage, abnormal noise, and vibration.

## 10.0 Drive Shaft Coupling

Use a flexible coupling to connect the pump shaft to an engine flywheel or electric motor shaft. Alignment [ $\delta$ ] should be within 0.001 in (0.025 mm) parallel and 0.2° angular [ $\alpha$ ] as shown in the illustration below.

Do not apply any axial loading to the pump shaft. For applications where radial, or side, loads exist please contact Kawasaki for recommendations and bearing life analysis.

Do not hammer the coupling on or off the pump keyed shaft. Use the threaded hole in the end of the pump shaft to fix or remove the coupling.

Dial Gauge [Reading "a"]  
 $\delta = a/2 \leq 0.001 \text{ in (0.025 mm)}$

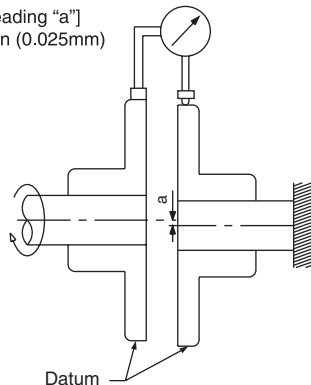

Dial Gauge [Reading "b"]  
 $\alpha = \sin^{-1}(b/D) \leq 0.2^\circ$

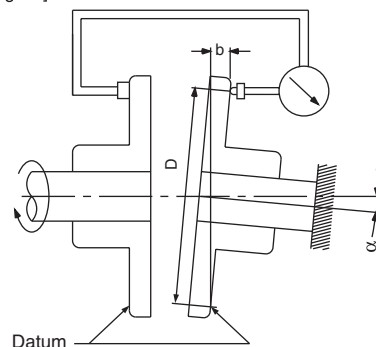

# 11.0 Installation Drawings

## K3VL28 With Cut-off/Load Sense Control And Torque Limit Module (Clockwise Rotation)

Inlet and outlet ports reversed for counter clockwise rotation

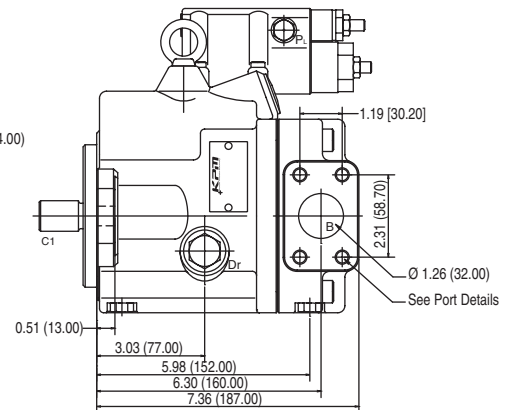
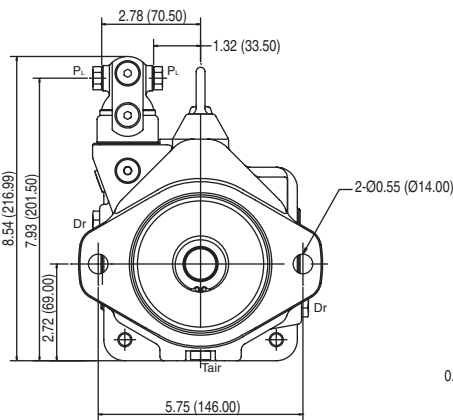
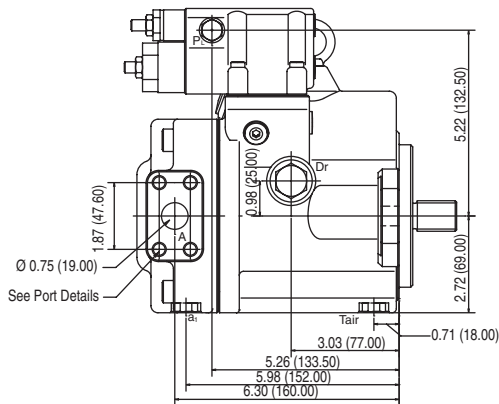
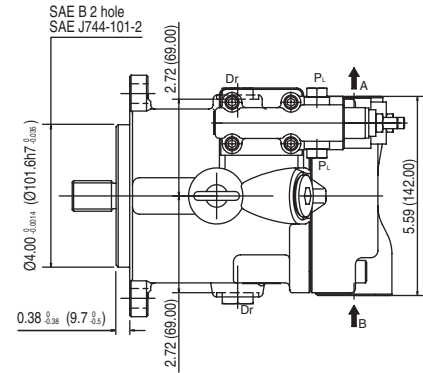
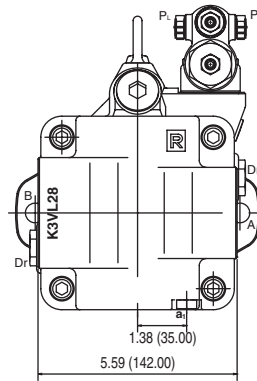

### Port Details

Port Name	Port Size and Description	Tightening Torque lbf-ft (Nm)
A	Delivery Port 1" SAE J518C Code 61 (5000 psi) Unified Thread Type "S": 3/8" - 16 - 2B (0.71" depth)	42 (57)
B	Inlet Port 1-1/2" SAE J518C Code 61 (3000 psi) Unified Thread Type "S": 1/2" - 13 - 2B (0.87" depth)	72 (98)
Dr	Drain Port "S" Type: 1/2" O-Ring Boss - SAE J1926/1 (3/4" - 16UNF - 2B)	72 (98)
P <sub>1</sub> / P <sub>2</sub>	PO/LO Control Port "S" Type: 1/4" O-Ring Boss - SAE J1926/1 (7/16" - 20UNF - 2B)	9 (12)
Tair	Air Bleed Port "S" Type: 1/4" O-Ring Boss - SAE J1926/1 (7/16" - 20UNF - 2B)	9 (12)

Dimensions shown in inches and (millimeters) unless noted otherwise.

# Mounting Flange

## Model Code Option "K"

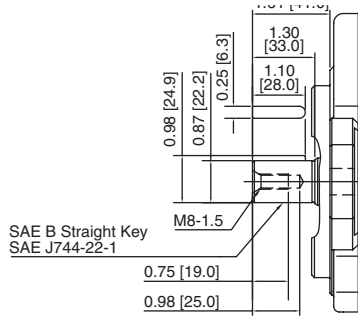

## Model Code Option "S"

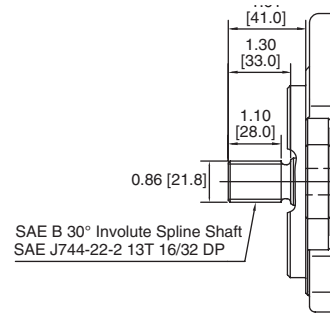

## K3VL28 Through Drive Installation Details

### SAE A

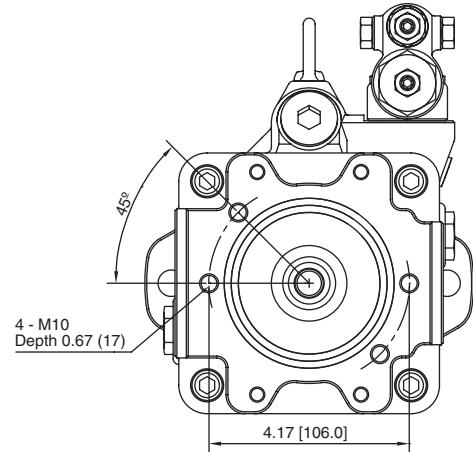
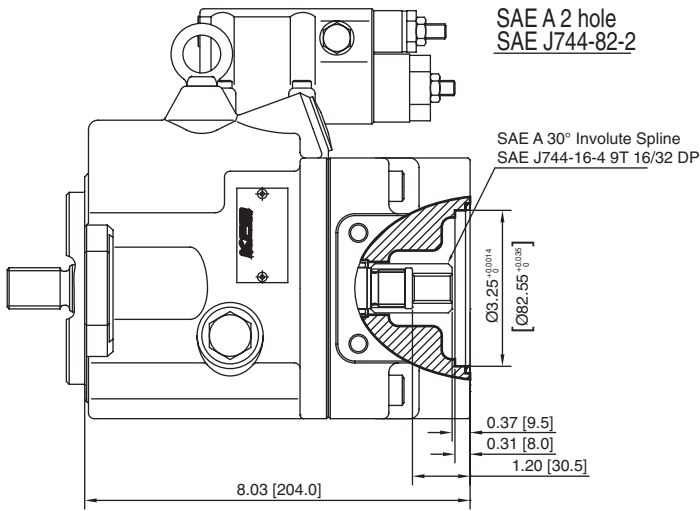

### SAE B

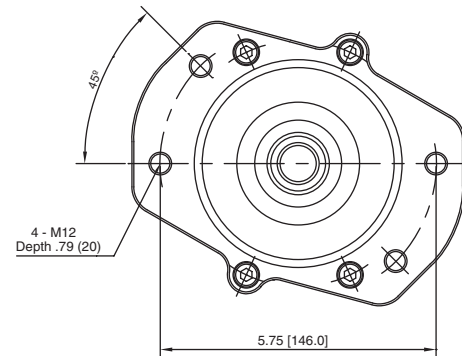
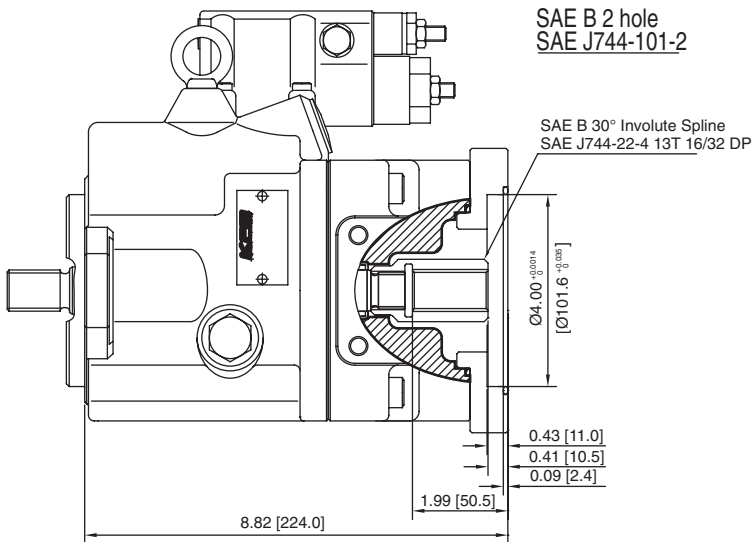

# 11.0 Installation Drawings

## K3VL45/60 With Cut-off/Load Sense Control And Torque Limit Module (Clockwise Rotation)

Inlet and outlet ports reversed for counter clockwise rotation

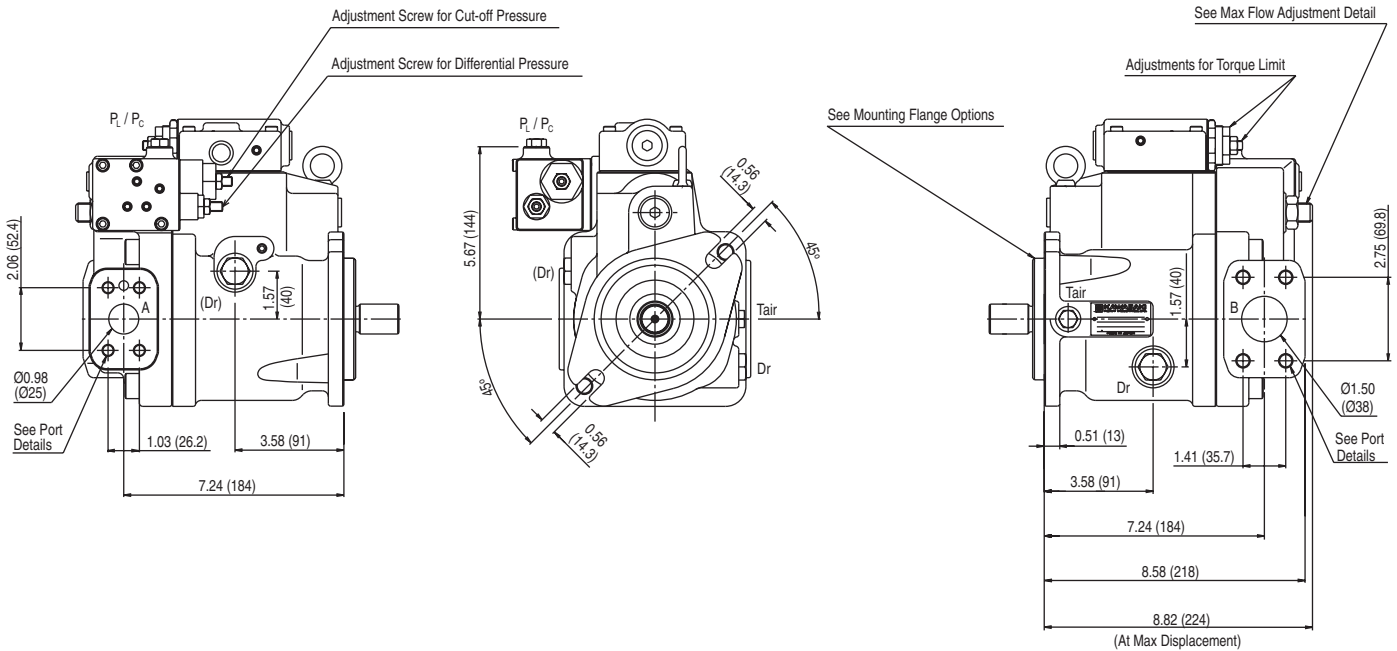
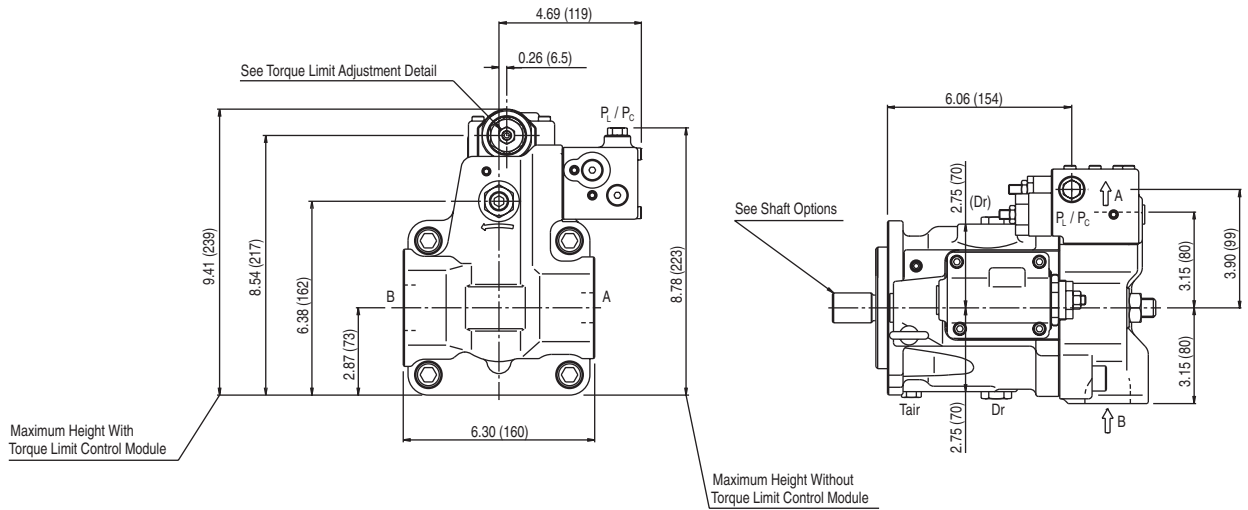

### Port Details

Port Name	Port Size and Description	Tightening Torque lbf-ft (Nm)
A	Delivery Port 1" SAE J518C Code 61 (5000 psi) Unified Thread Type "S": 3/8" - 16 - 2B (0.71" depth)	42 (57)
B	Inlet Port 1-1/2" SAE J518C Code 61 (3000 psi) Unified Thread Type "S": 1/2" - 13 - 2B (0.87" depth)	72 (98)
Dr	Drain Port "S" Type: 1/2" O-Ring Boss - SAE J1926/1 (3/4" - 16UNF - 2B)	72 (98)
P <sub>L</sub> / P <sub>C</sub>	PO/LO Control Port "S" Type: 1/4" O-Ring Boss - SAE J1926/1 (7/16" - 20UNF - 2B)	9 (12)
Tair	Air Bleed Port "S" Type: 1/4" O-Ring Boss - SAE J1926/1 (7/16" - 20UNF - 2B)	9 (12)

Dimensions shown in inches and (millimeters) unless noted otherwise.

# Mounting Flange

## Model Code Options "K" or "S"

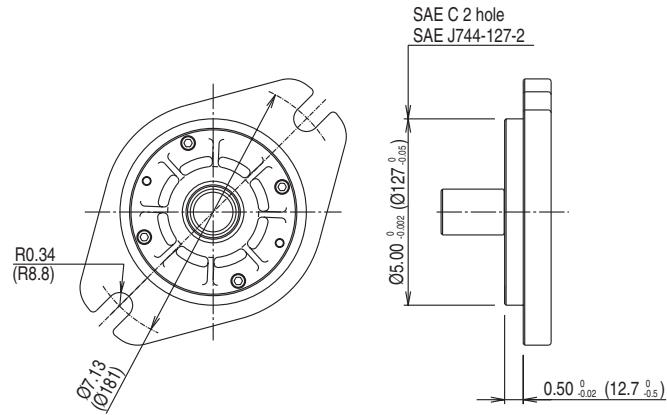

# Shafts

## Model Code Option "K"

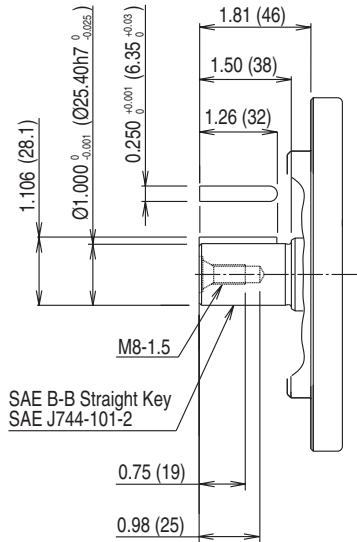

## Model Code Option "S"

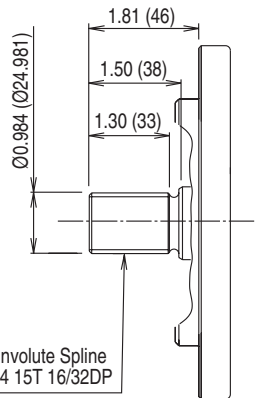

## Model Code Option "T"

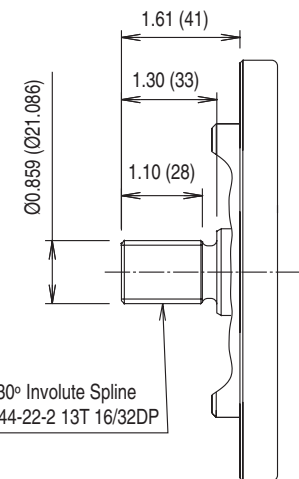

# Rear Ports

## Model Code Option "R"

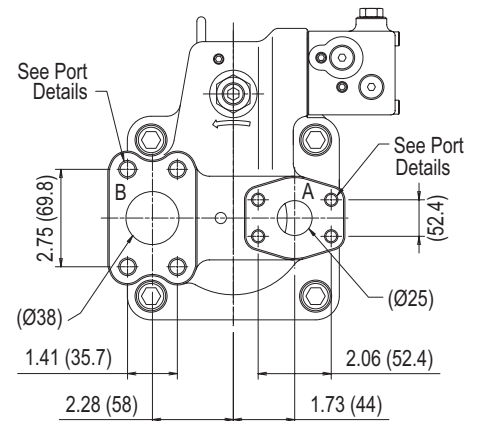
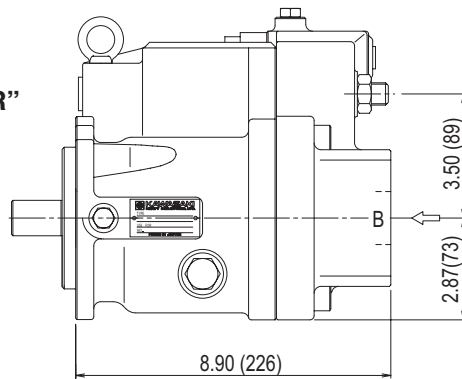

# 11.0 Installation Drawings (Continued)

## K3VL80 With Cut-off/Load Sense Control And Torque Limit Module (Clockwise Rotation)

Inlet and outlet ports reversed for counter clockwise rotation

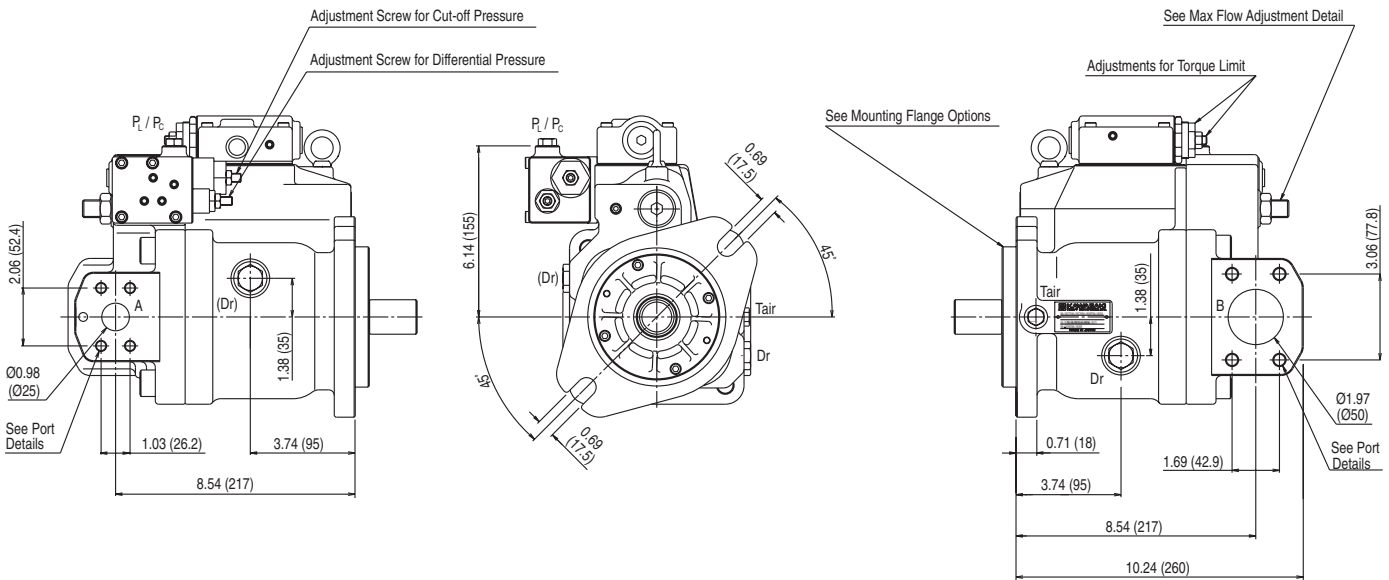
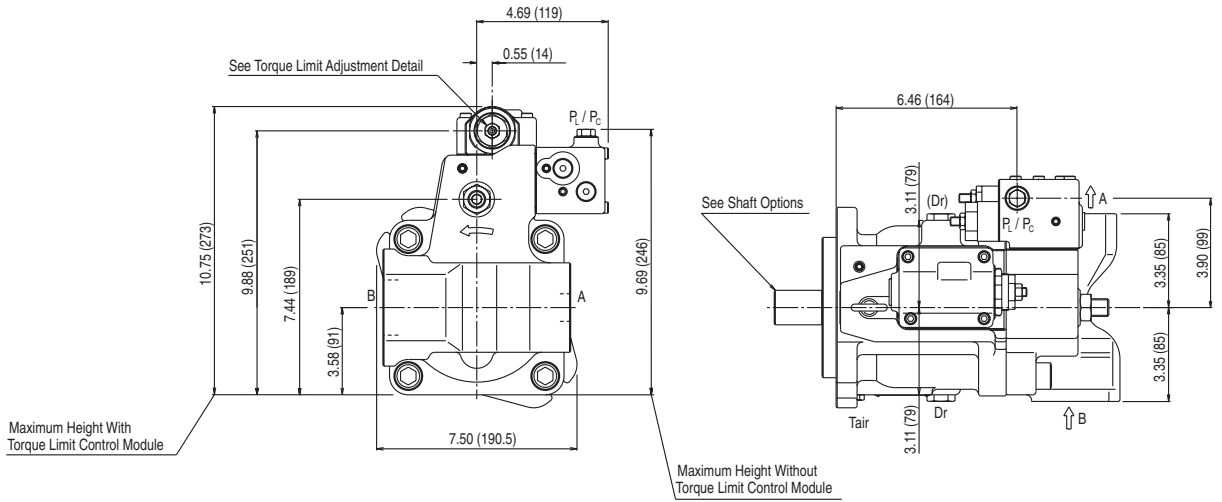

### Port Details

	Port Name	Port Size and Description	Tightening Torque lbf-ft (Nm)
A	Delivery Port	1" SAE J518C Code 61 (5000 psi)	
		Unified Thread Type "S": 3/8" - 16 - 2B (0.71" depth)	42 (57)
B	Inlet Port	1-1/2" SAE J518C Code 61 (3000 psi)	
		Unified Thread Type "S": 1/2" - 13 - 2B (0.87" depth)	72 (98)
Dr	Drain Port	"S" Type: 1/2" O-Ring Boss - SAE J1926/1 (3/4" - 16UNF - 2B)	72 (98)
P <sub>1</sub> / P <sub>2</sub>	PO/L0 Control Port	"S" Type: 1/4" O-Ring Boss - SAE J1926/1 (7/16" - 20UNF - 2B)	9 (12)
Tair	Air Bleed Port	"S" Type: 1/4" O-Ring Boss - SAE J1926/1 (7/16" - 20UNF - 2B)	9 (12)

Dimensions shown in inches and (millimeters) unless noted otherwise.

# Mounting Flange

## Model Code Options "K" or "S"

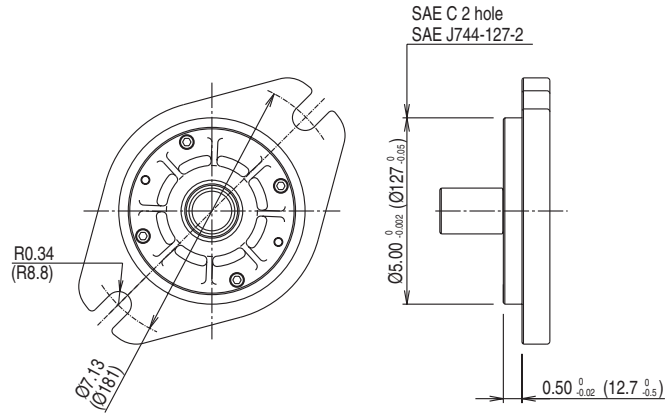

# Shafts

## Model Code Option "K"

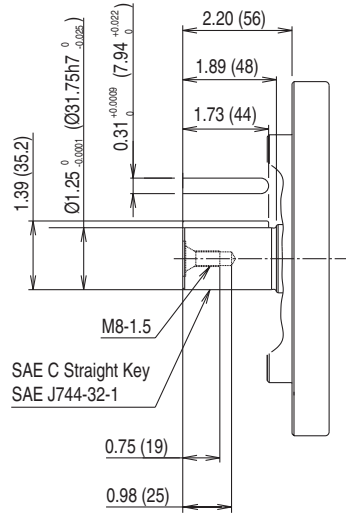

## Model Code Option "S"

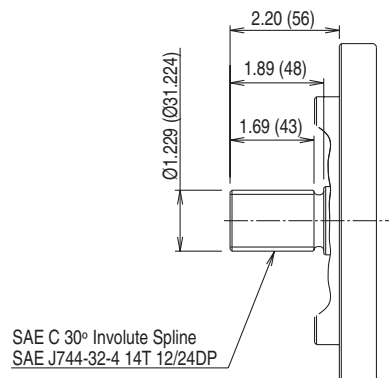

# Rear Ports

## Model Code Option "R"

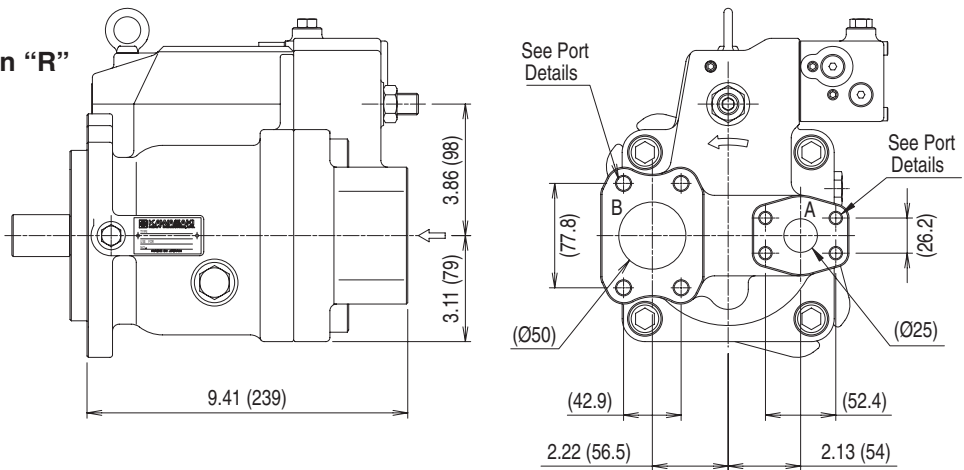

# 11.0 Installation Drawings (Continued)

## K3VL112/140 With Cut-off/Load Sense Control And Torque Limit Module (Clockwise Rotation)

Inlet and outlet ports reversed for counter clockwise rotation

### Standard Mounting (SAE D)

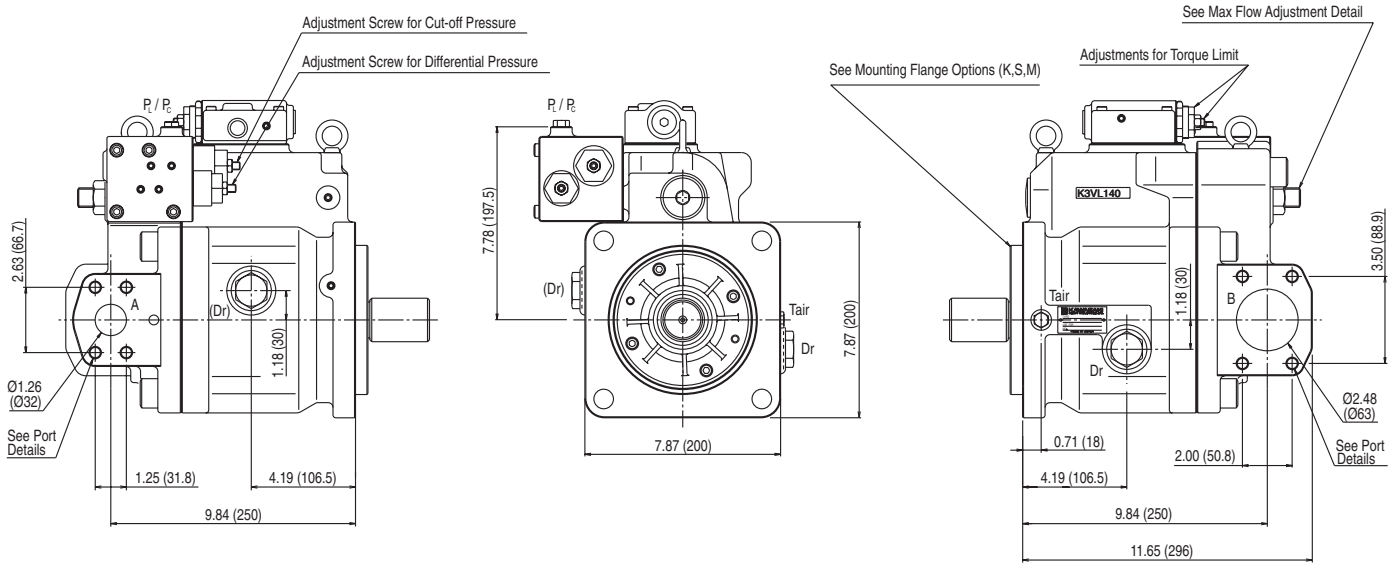
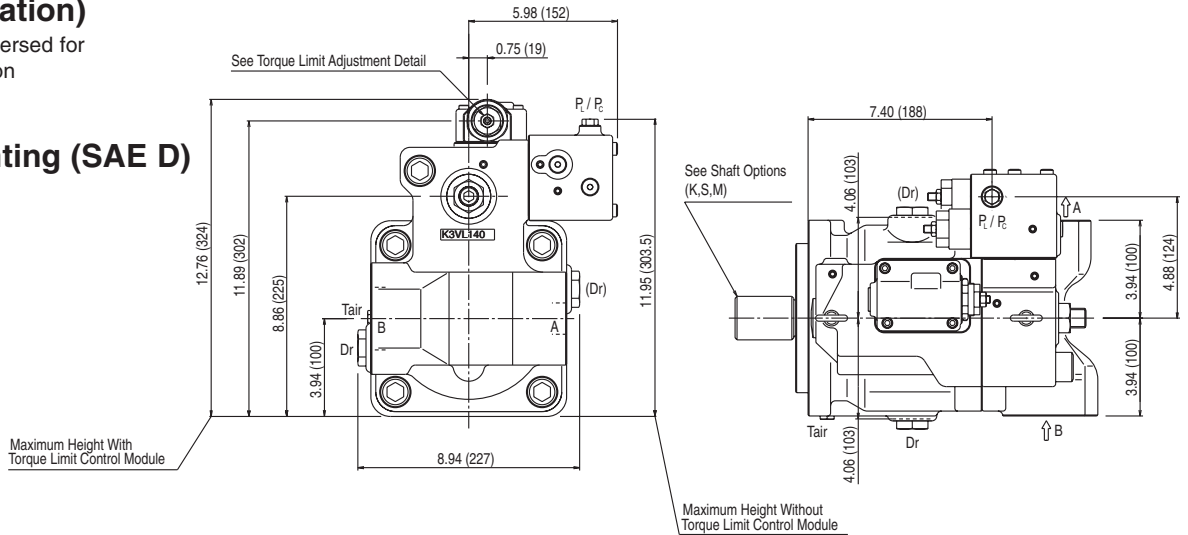

### Port Details

Port Name	Port Size and Description	Tightening Torque lbf-ft (Nm)	
A	Delivery Port	1-1/4" SAE J518C Code 62 (6000 psi)	
	Unified Thread Type "S": 1/2" - 13 - 2B (0.87" depth)	72 (98)	
B	Inlet Port	2-1/2" SAE J518C Code 61 (2500 psi)	
	Unified Thread Type "S": 1/2" - 13 - 2B (0.87" depth)	72 (98)	
Dr	Drain Port	"S" Type: 3/4" O-Ring Boss - SAE J1926/1 (1-1/6" - 12UNF - 2B)	123 (167)
P <sub>r</sub> /P <sub>o</sub>	PO/LO Control Port	"S" Type: 1/4" O-Ring Boss - SAE J1926/1 (7/16" - 20UNF - 2B)	9 (12)
Tair	Air Bleed Port	"S" Type: 1/4" O-Ring Boss - SAE J1926/1 (7/16" - 20UNF - 2B)	9 (12)

Dimensions shown in inches and (millimeters) unless noted otherwise.

# Optional Mounting (SAE C)

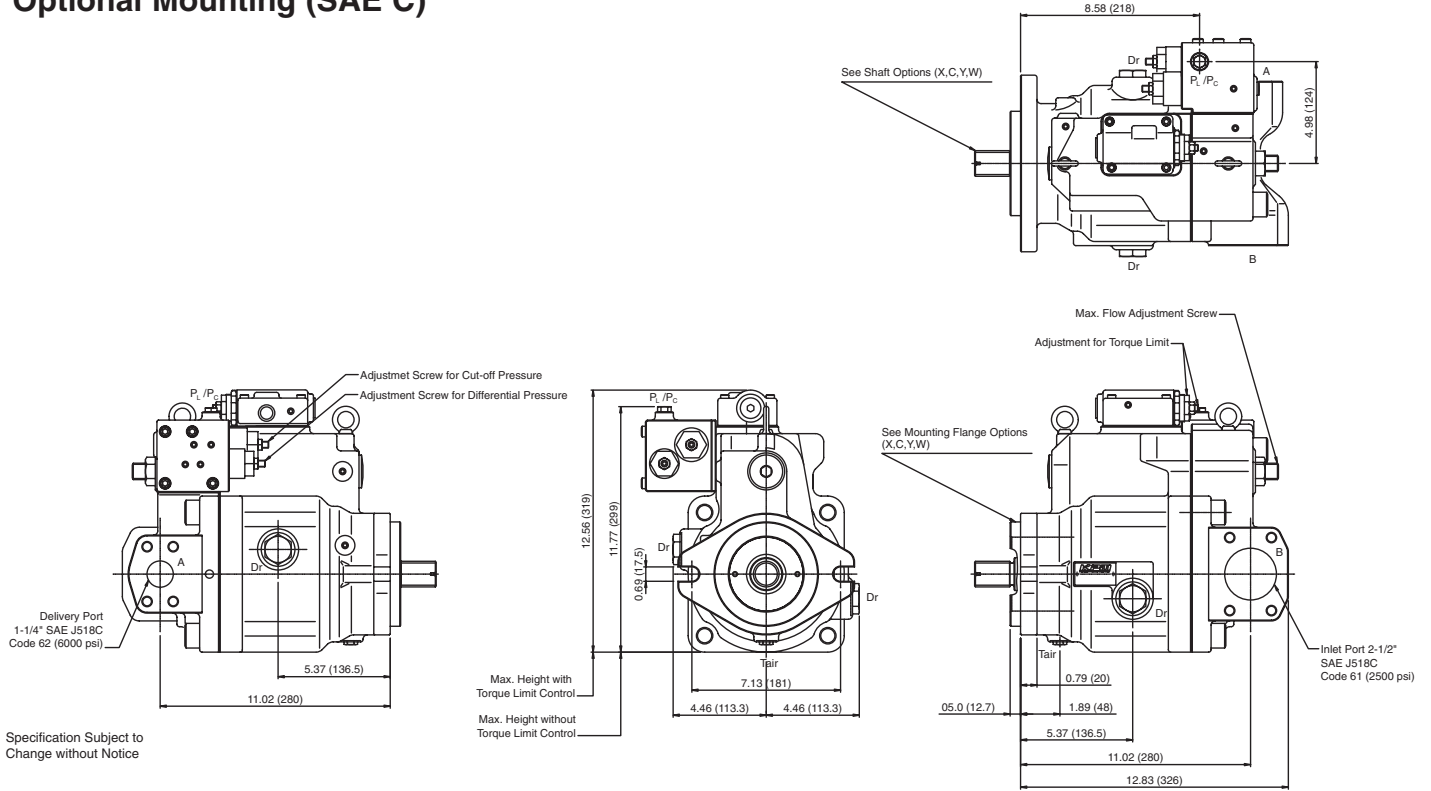

# Shafts

Model Code Option "K"

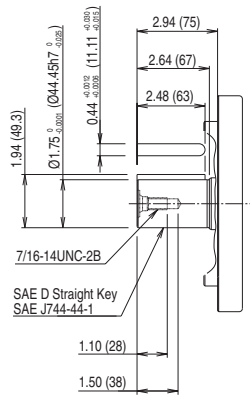

Model Code Option "S"

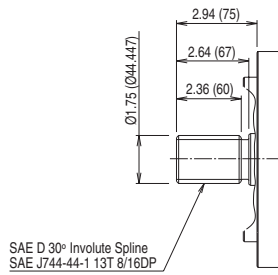

Model Code Option "X"

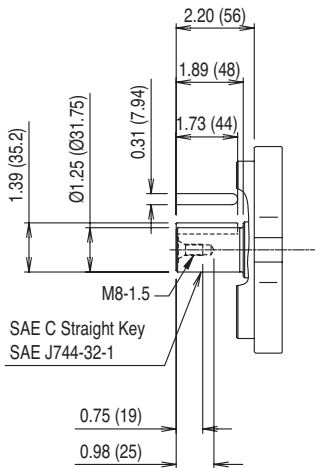

Model Code Option "C"

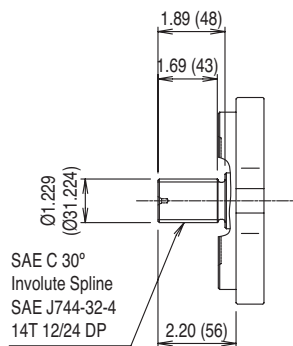

Model Code Option "Y"

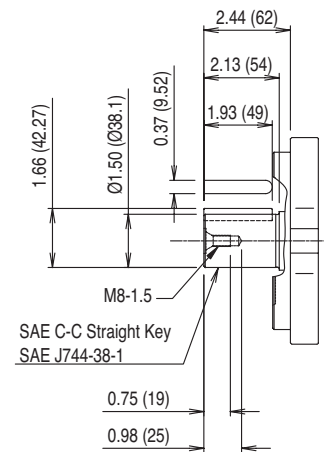

Model Code Option "W"

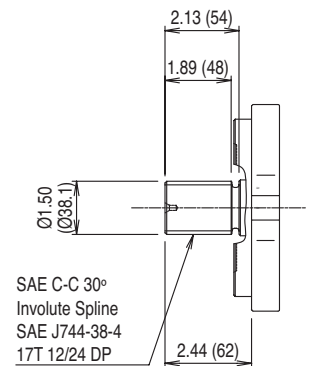

# 11.0 Installation Drawings (Continued)

## K3VL112/140

### Mounting Flanges

#### Model Code Options "K" or "S"

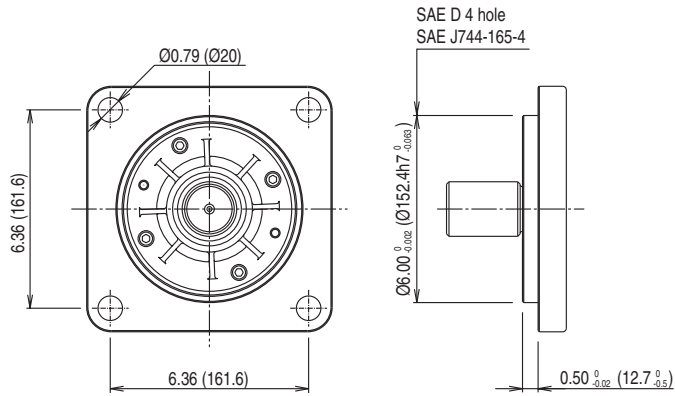

#### Model Code Options "C", "X", "W" or "Y"

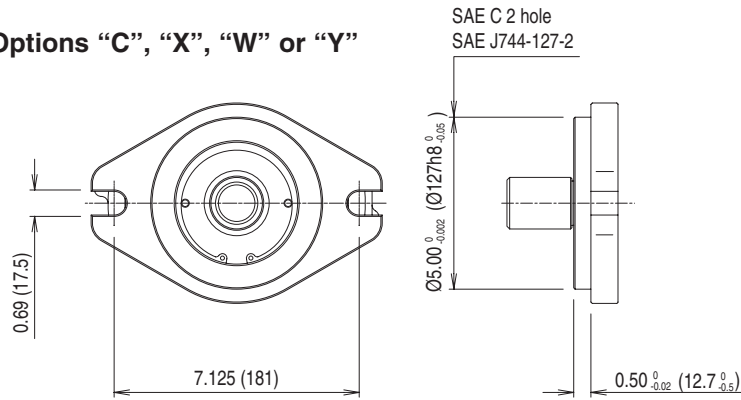

### Rear Ports

#### Model Code Option "R"

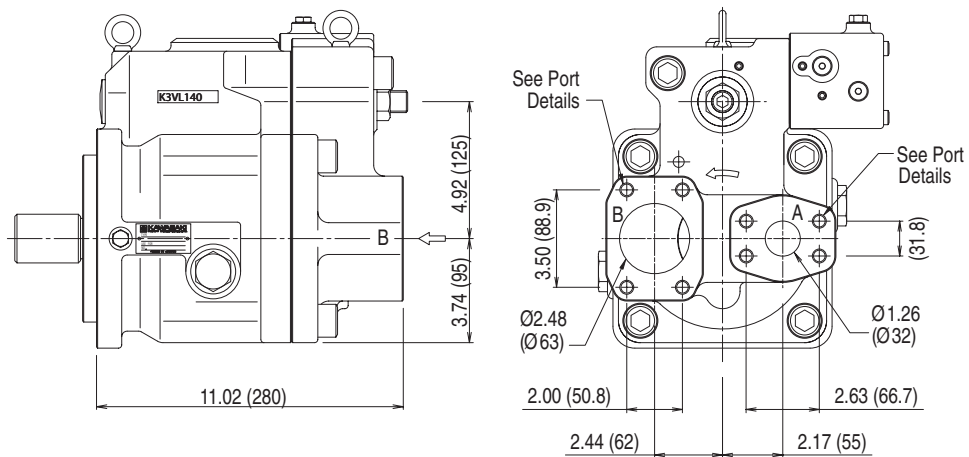

# 11.0 Installation Drawings (Continued)

## K3VL200 With Cut-off/Load Sense Control And Torque Limit Module (Clockwise Rotation)

Inlet and outlet ports reversed  
for counter clockwise rotation

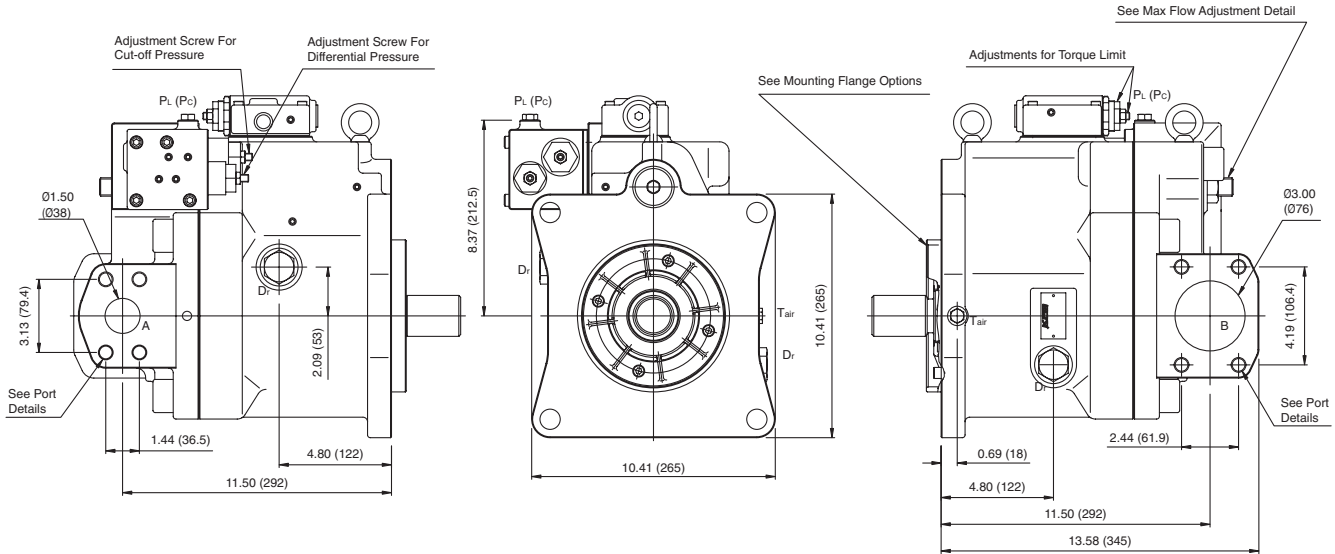
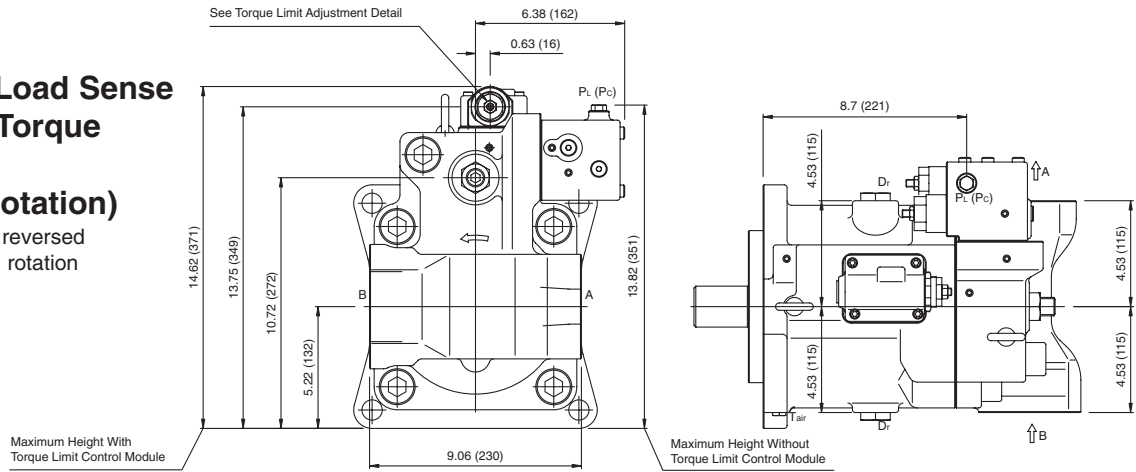

## Mounting Flange

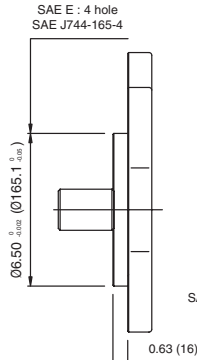
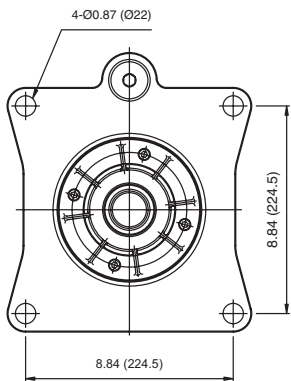

### Model Code Option "S"

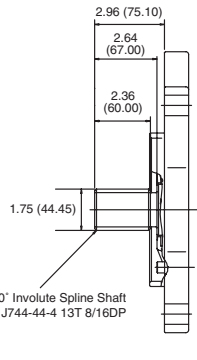

### Model Code Option "K"

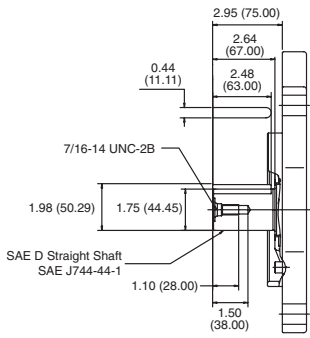

### Model Code Option "F"

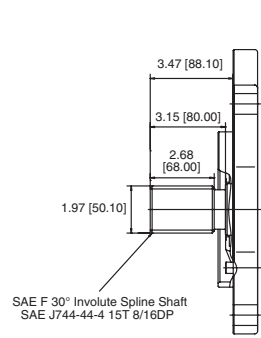

## Port Details

	Port Name	Port Size and Description	Tightening Torque lbf-ft (Nm)
A	Delivery Port	1-1/2" SAE J518C Code 62 (6000 psi)	173 (235)
		Unified Thread Type "S": 5/8" - 11 - 2B (.98" depth)	
B	Inlet Port	3" SAE J518C Code 61 (2000 psi)	173 (235)
		Unified Thread Type "S": 5/8" - 11 - 2B (.98" depth)	
Dr	Drain Port	"S" Type: 3/4" O-Ring Boss - SAE J1926/1 (1-1/6" - 12UNF - 2B)	123 (167)
P <sub>L</sub> / P <sub>C</sub>	PO/LO Control Port	"S" Type: 1/4" O-Ring Boss - SAE J1926/1 (7/16" - 20UNF - 2B)	9 (12)
T <sub>air</sub>	Air Bleed Port	"S" Type: 1/4" O-Ring Boss - SAE J1926/1 (7/16" - 20UNF - 2B)	9 (12)

Dimensions shown in inches and (millimeters) unless noted otherwise.

# 12.0 Response Time

## Pressure Cut-off Dynamic Response

### 50 to 280 bar (725 to 4060 psi)

Unit	$t_{off-stroke}$	$t_{on-stroke}$
	mS	
K3VL28	20	40
K3VL45/60	60	100
K3VL60	60	100
K3VL80	95	170
K3VL112	90	140
K3VL140	90	140
K3VL200	110	240

**Test Conditions:**

Pump Speed = 1800 rpm  
 Inlet Condition = 0 psi (bar)  
 Oil Type = ISO VG46  
 Oil Temperature = 122°F (50°C)  
 Compressed Oil Volume = 1.32 gallons (5 liters)

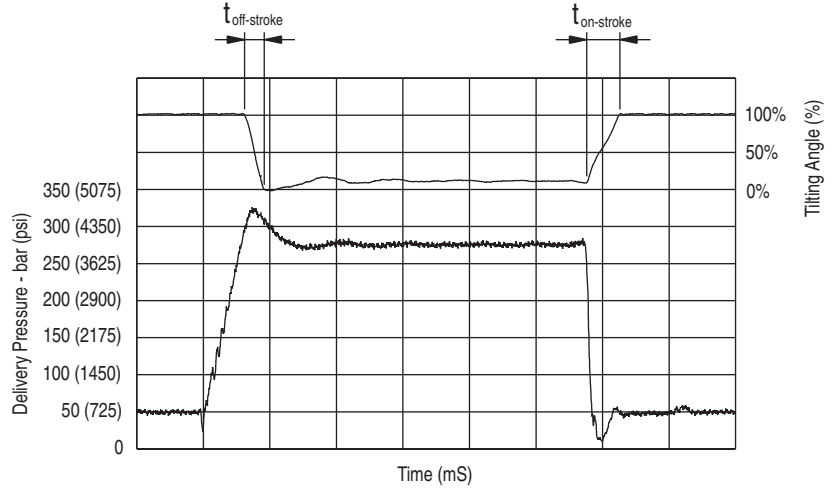

### 220 to 280 bar (3190 to 4060 psi)

Unit	$t_{off-stroke}$	$t_{on-stroke}$
	mS	
K3VL28	20	40
K3VL45/60	60	70
K3VL60	60	70
K3VL80	100	110
K3VL112	100	120
K3VL140	100	120
K3VL200	110	220

**Test Conditions:**

Pump Speed = 1800 rpm  
 Inlet Condition = 0 psi (bar)  
 Oil Type = ISO VG46  
 Oil Temperature = 122°F (50°C)  
 Compressed Oil Volume = 1.32 gallons (5 liters)

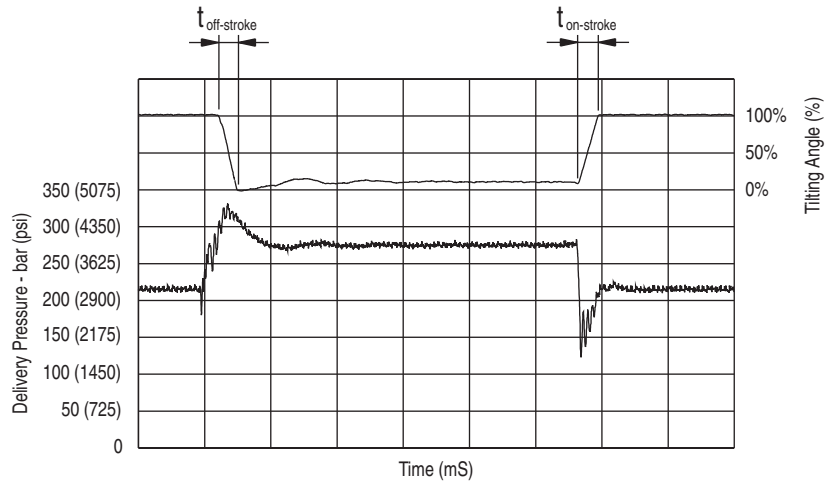

## Load Sensing Dynamic Response

### 20 to 280 bar (290 to 4060 psi)

Unit	$t_{off-stroke}$	$t_{on-stroke}$
	mS	
K3VL28	20	70
K3VL45/60	20	115
K3VL60	20	115
K3VL80	55	155
K3VL112	55	195
K3VL140	55	195
K3VL200	65	190

**Test Conditions:**

Pump Speed = 1800 rpm  
 Inlet Condition = 0 psi (bar)  
 Oil Type = ISO VG46  
 Oil Temperature = 122°F (50°C)  
 Compressed Oil Volume = 1.32 gallons (5 liters)

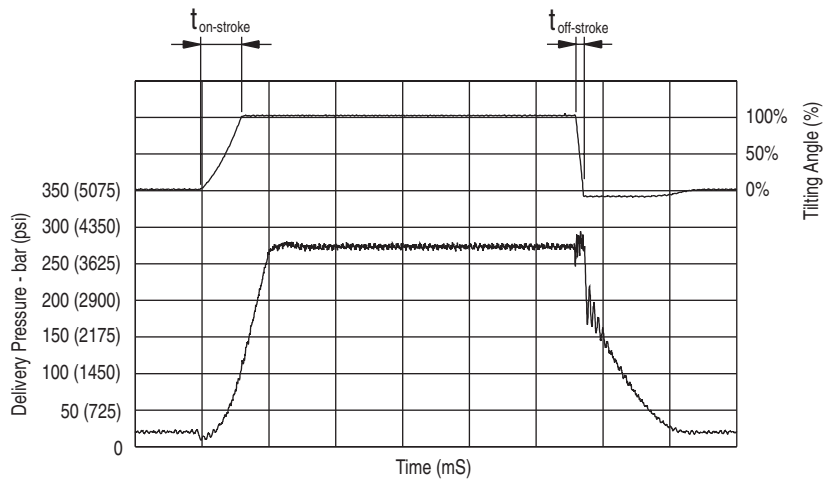

**Note:** The response values shown in the tables above are typical of those experienced in the laboratory. Actual response time will vary with different hydraulic circuits.

# 13.0 Through Drives

Pump Frame Size (K3VL cc/rev)		45,60,80,112,140,200			80,112,140,200			112,140,200	200	
		28								
Mounting Code		A	B	BB	C4	C	CC	D	E	
Dimensions [in (mm)]	Pilot Diameter	3.25 (82.55)	4.000 (101.60)		5.000 (127.0)			6.000 (152.4)	6.50 (165.1)	
	Pilot Depth	0.315 (8.0)	0.433 (11.0)		0.551 (14.0)			0.551 (14.0)	0.710 (18)	
	Mounting Bolt Hole Thread	M10 - 1.5	M12 - 1.75		M12 - 1.75	M16 - 2.0			M20 - 2.5	
	Shaft Length	1.358 (34.5)	1.929 (46.0)		2.185 (55.5)			2.756 (70.0)		
	Spline Engagement	0.984 (25.0)	1.535 (39.0)		1.772 (45.0)			2.480 (63.0)		
Shaft Spline Detail [in (mm)]	Standard	SAE Flat Root Side Fit - Tolerance Class 5								
	Number of Teeth	9	13	15	14	17	13			
	Diametral Pitch	16/32			12/24			8/16		
	Pressure Angle	30°								
	Major Diameter	0.625 (15.875)	0.875 (22.225)	1.000 (25.4)	1.283 (32.588)	1.533 (38.938)	1.850 (46.990)			
	Internal Diameter Over Pins	0.397 (10.089)	0.653 (16.589)	0.780 (19.807)	0.961 (24.407)	1.207 (30.648)	1.301 (33.056)			
	Pin Diameter	0.108 (2.743)			.0.144 (3.658)			0.216 (5.486)		
<b>Allowable Torque [lbf-ft (Nm)]</b>		45 (31)	150 (203)	166 (226)	295 (400)	412 (559)	516 (699)			

## Kit Detail

### SAE A Kit (K3VL 45~140)

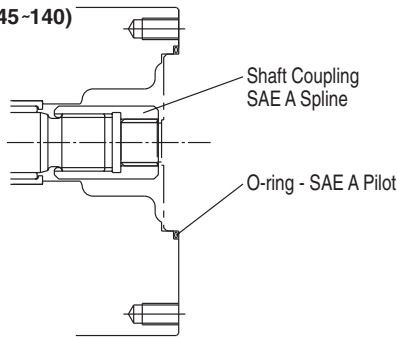

### SAE B-D Kits (K3VL 45~140)

### SAE A-E Kits (K3VL 200)

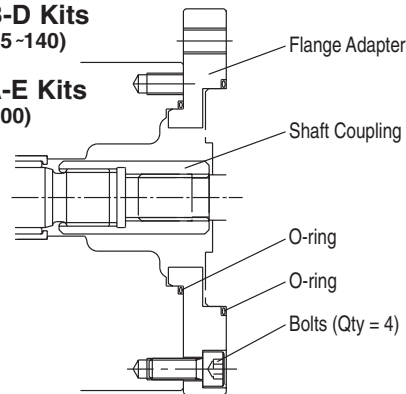

**CAUTION:** Second pump should have solid pilot so o-ring can seal against the corner.

## Bending Moment Limitation

	Symbol	Units	K3VL28	K3VL45/60	K3VL80	K3VL112/140	K3VL200
Maximum Allowable Bending Moment	Bmax	lbf-ft (Nm)	81 (110)	101 (137)	180 (244)	341 (462)	685 (930)
Pump Weight Without Through Drive	M	lb (kg)	44 (20)	55 (25)	77 (35)	143 (65)	209 (95)
Pump Weight With SAE A Through Drive	Ma	lb (kg)	44 (20)	62 (28)	84 (38)	152 (69)	226 (103)
Pump Weight With SAE B/BB Through Drive	Mb	lb (kg)	48 (22)	73 (33)	97 (44)	167 (76)	249 (113)
Pump Weight With SAE C/CC Through Drive	Mc	lb (kg)	-	-	99 (45)	172 (78)	249 (113)
Pump Weight With SAE D Through Drive	Md	lb (kg)	-	-	-	183 (83)	253 (115)
Pump Weight With SAE E Through Drive	Me	lb (kg)	-	-	-	-	264 (120)
Distance from Mounting Face to Pump Center of Gravity Not Including Through Drive Kit	d2	in (mm)	4.33 (110)	4.72 (120)	5.12 (130)	5.91 (150)	7.48 (190)
Distance from Mounting Face to Pump Center of Gravity Including Through Drive Kit (Approximation)	d1	in (mm)	4.72 (120)	5.12 (130)	5.71 (145)	6.89 (175)	8.47 (215)
Through Drive Pump Length from Front to Rear Mounting Flanges	D#	in (mm)	Page 19	See Page 30 With through drive pump length			Page 31

Bending moment for tandem pump = [Ma-e x d1] + [M x (d2 + D#)]. If the result exceeds the maximum allowable bending moment, then additional support is required. Consult Kawasaki in this case.

# K3VL45 – 140 Through Drive Installation Details

**SAE A** SAE A 2 hole  
SAE J744-82-2

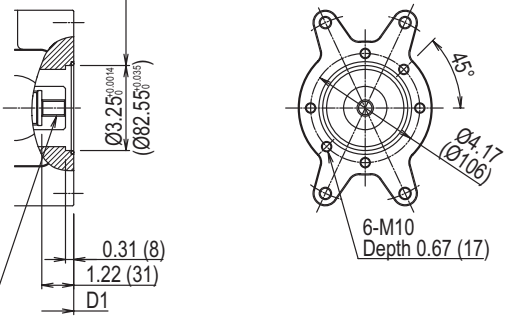

SAE A 30° Involute Spline  
SAE J744-16-4 9T 16/32DP

**SAE B** SAE B 2 hole  
SAE J744-101-2

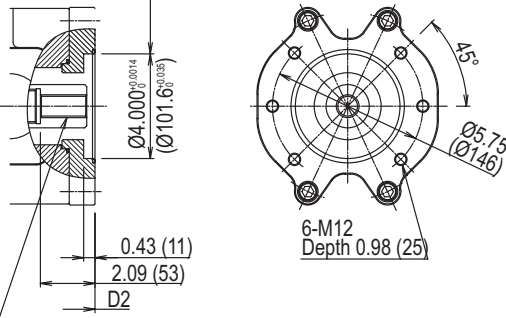

SAE B 30° Involute Spline  
SAE J744-22-4 13T 16/32DP

**SAE B-B** SAE BB 2 hole  
SAE J744-101-2

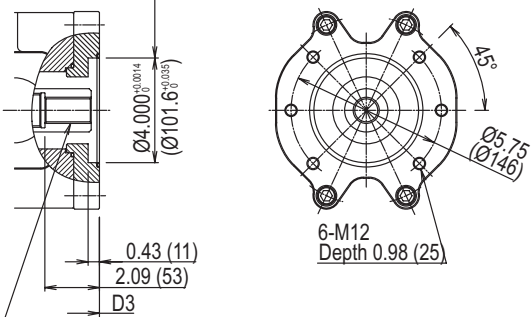

SAE BB 30° Involute Spline  
SAE J744-25-4 15T 16/32DP

**SAE C** SAE C 2 hole  
SAE J744-127-2

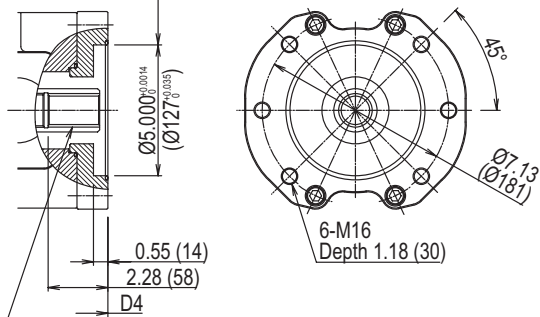

SAE C 30° Involute Spline  
SAE J744-33-4 14T 12/24DP

SAE C 4 hole  
4.500<sup>+0.007</sup>  
(114.5<sup>+0.20</sup>)

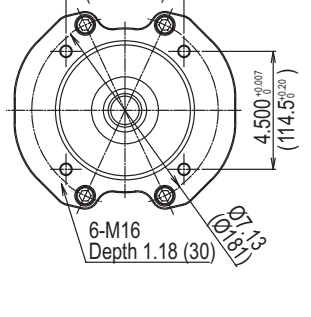

**SAE C-C** SAE CC 2 hole  
SAE J744-127-2

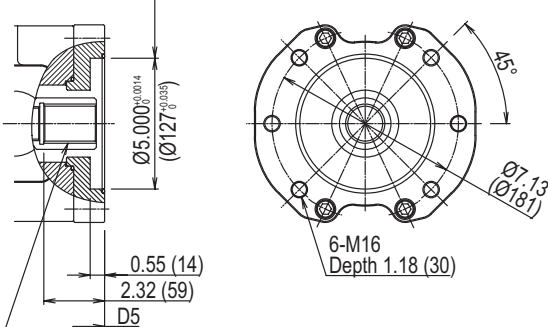

SAE CC 30° Involute Spline  
SAE J744-38-4 17T 12/24DP

SAE CC 4 hole  
4.500<sup>+0.007</sup>  
(114.5<sup>+0.20</sup>)

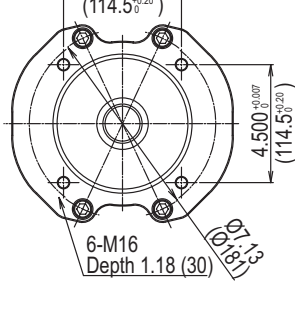

**SAE D** SAE D 4 hole  
SAE J744-152-2

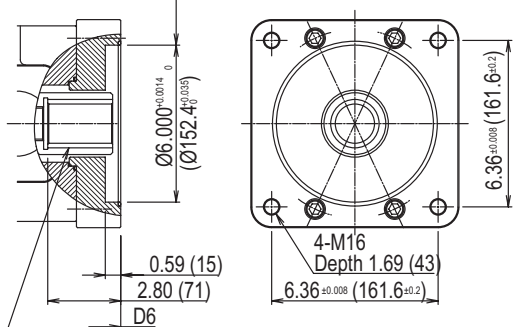

SAE D 30° Involute Spline  
SAE J744-47-4 13T 8/16DP

## Through Drive Pump Length From Front to Rear Mounting Flanges

Note	Interface	Units	K3VL45/60	K3VL80	K3VL112/140	K3VL200
D1	SAE A	in (mm)	9.61 (244.0)	10.71 (272.0)	12.11 (307.5)	14.37 (365)
D2	SAE B		10.39 (264.0)	11.50 (292.0)	13.09 (332.0)	15.12 (384)
D3	SAE B-B		-	11.50 (292.0)	13.09 (332.0)	15.12 (384)
D4	SAE C		-	11.67 (296.5)	13.29 (337.5)	15.12 (384)
D5	SAE C-C		-	-	-	15.12 (384)
D6	SAE C-4		-	-	-	15.12 (384)
D7	SAE D		-	-	13.80 (350.5)	15.63 (397)
D8	SAE E		-	-	-	15.63 (397)

**WARNING:** Do not attempt to use UNC threaded bolts in METRIC bolt holes.

# K3VL200 Through Drive Installation Details

## SAE A

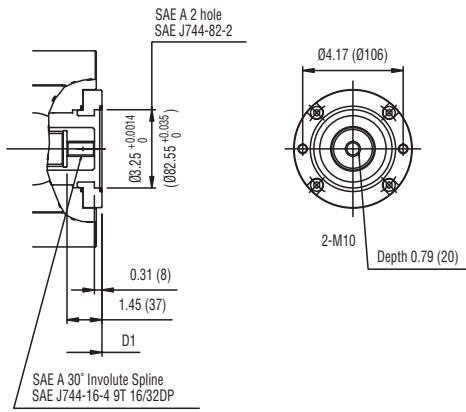

## SAE B

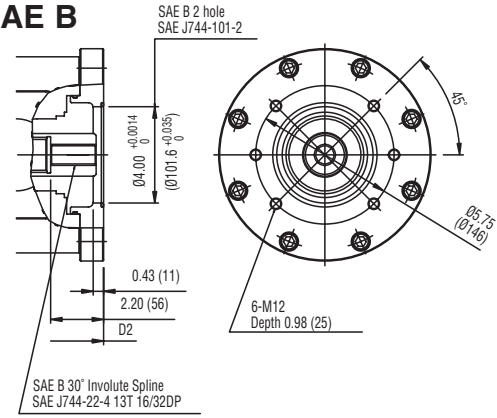

## SAE B-B

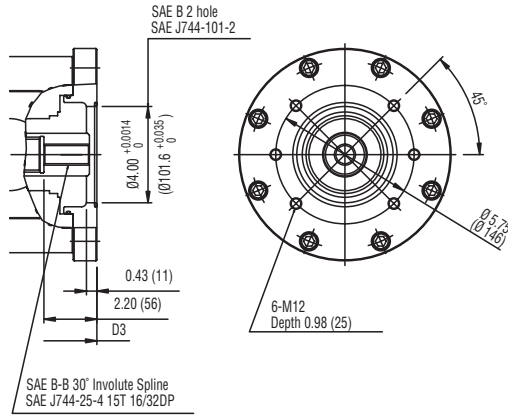

## SAE C-2

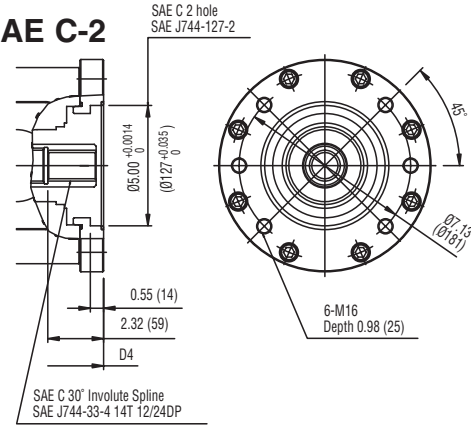

## SAE C-C

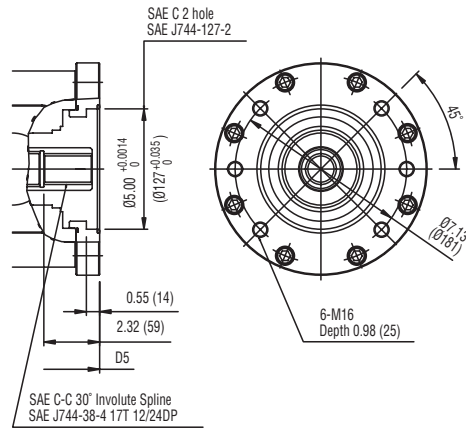

## SAE C-4

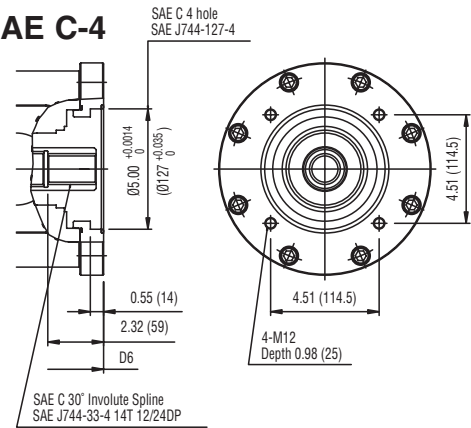

## SAE D

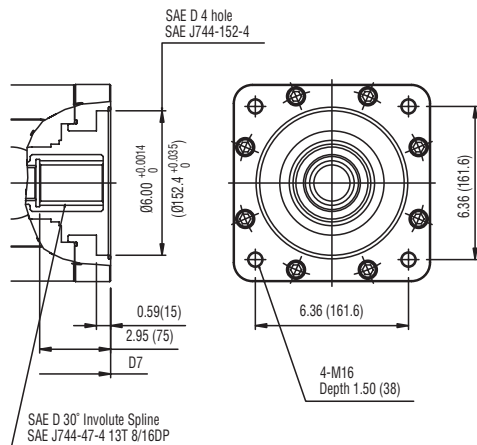

## SAE E

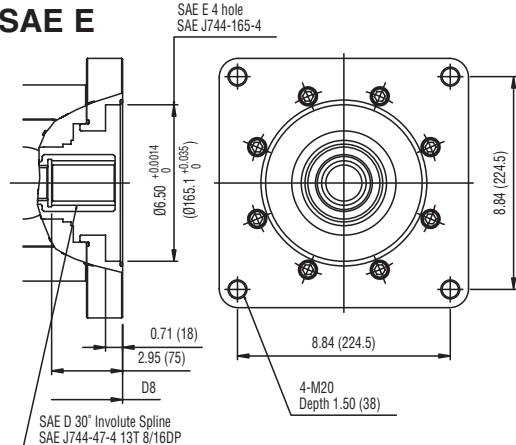

# 14.0 Pump Controls

## Max Flow Adjustment

Flow Adjustment	Unit	K3VL45	K3VL60	K3VL80	K3VL112	K3VL140	K3VL200
Adjustment Screw: Internal Hex size	mm	8	8	8	10	10	10
Displacement Per Screw Revolution	in <sup>3</sup> (cm <sup>3</sup> )	0.3 (4.9)	0.37 (6.1)	0.36 (6.0)	0.70 (11.5)	0.73 (12.0)	0.93 (15.3)
Displacement Adjustment Range	in <sup>3</sup> (cm <sup>3</sup> )	0.98 - 2.75 (16 - 45)	1.65 - 3.70 (24 - 60)	2.15 - 4.88 (35 - 80)	3.42 - 6.83 (56 - 112)	4.27 - 8.54 (70 - 140)	6.1 - 12.2 (100 - 200)
Exposed Screw Length (L)	in (mm)	0.02 - 0.47 (0.5 - 12.1)	0.02 - 0.47 (0.5 - 12.1)	0.02 - 0.59 (0.5 - 15.0)	0.14 - 0.63 (3.8 - 16)	0.04 - 0.63 (1.0 - 16)	0.35 - 1.00 (8.9 - 25.3)
Lock-nut Hex Size	mm	24	24	24	30	30	30
Lock-nut Tightening Torque	lbf-ft (Nm)	94 (128)	94 (128)	94 (128)	173 (235)	173 (235)	173 (235)

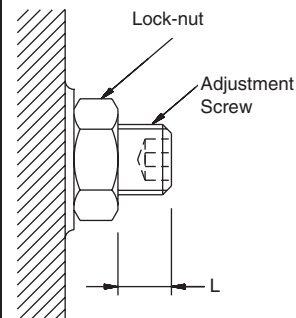

## Pressure Cut-off or Load Sense (P0/L0) Control Regulator

P0/L0 Regulator Adjustment	Unit	K3VL28	K3VL45/60/80	K3VL112/140/200
Cut-off/Load Sense Adjustment Screws: Internal Hex Size	mm	4	4	4
Cut-off Pressure Change Per Screw Revolution <sup>*1</sup>	psi (bar)	1160 (80)	580 (40)	1330 (92)
Differential Pressure Change Per Screw Revolution <sup>*1</sup>	psi (bar)	188 (13)	188 (13)	80 (5.5)
Cut-off/Load Sense Adjustment Screws: Lock-nut Hex Size	mm	13	13	13
Lock-nut Tightening Torque	lb <sub>r</sub> -ft (Nm)	12 (16)	12 (16)	12 (16)

\*1 Turning the adjustment screw clockwise increases the setting.

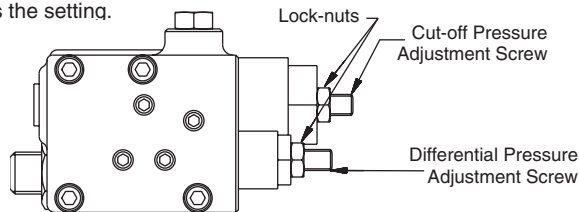

## Torque Limit Control Module

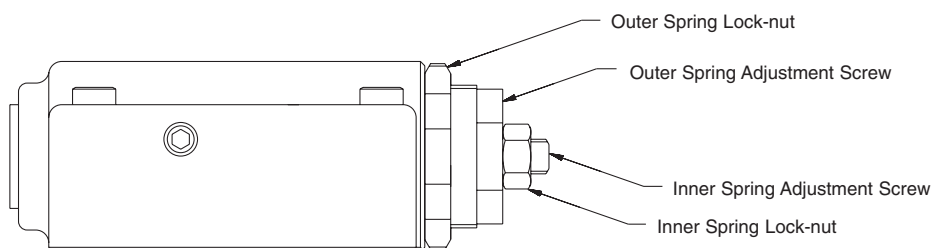

### Torque Limit P-Q Curve

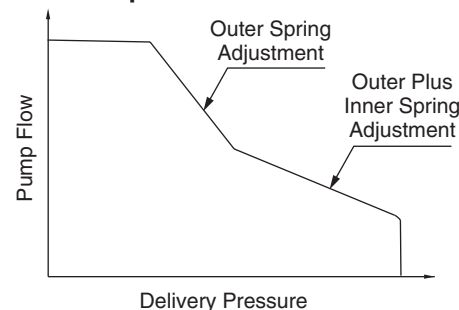

## Torque Limit Control Module Adjustments

Outer Spring Adjustment Screws: External Hex Size	mm	27
Outer Spring Lock-nut Size	mm	41
Outer Spring Lock-nut Tightening Torque	lb <sub>r</sub> -ft (Nm)	75 (102)
Inner Spring Adjustment Screw: Internal Hex Size	mm	4
Inner Spring Lock-nut Size	mm	13
Inner Spring Lock-nut Tightening Torque	lb <sub>r</sub> -ft (Nm)	12 (16)

### Adjusting the K3VL torque limiter.

The torque limiter has two adjustments, one for the outer spring and the other for the inner spring. The outer spring adjustment changes the top half of the PQ curve and the inner spring adjustment will change the bottom half. A clockwise adjustment will increase the setting. A change to the outer adjustment will change the setting of both the inner and outer springs; the inner adjustment has no effect on the outer adjustment. Adjust the outer adjustment first, then the inner.

Each torque limited pump is factory preset to a specific horsepower setting. Refer to the horsepower designation charts on page 3.

# 15.0 Integral Unloading Valve, Proportional Unloading Valve, Electronic Displacement Control

## Installation Dimensions

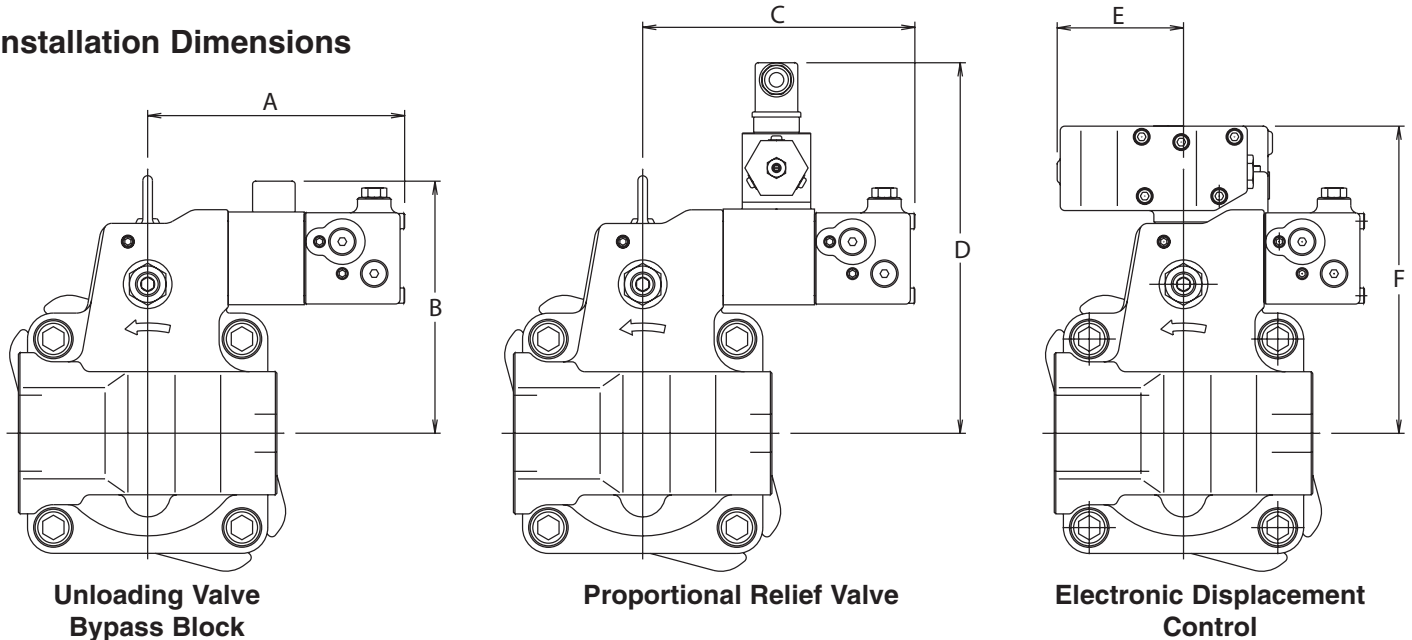

**Unloading Valve**  
LM, LN, PM, PN, LV2, PV2

**Bypass Block**  
\*B or \*D

**Proportional Relief Valve**  
PV or LV

	A	B
K3VL45/60	6.65 (169)	6.10 (155)
K3VL80	6.65 (169)	6.54 (166)
K3VL112/140	7.95 (202)	7.48 (190)
K3VL200	8.35 (212)	8.07 (205)

A	B
5.56 (141)	5.91 (169)
5.56 (141)	6.11 (155)
6.85 (174)	8.01 (203)
7.25 (184)	8.60 (219)

C	D
6.65 (169)	9.17 (233)
6.65 (169)	9.61 (244)
7.95 (202)	11.02 (280)
8.35 (212)	11.61 (295)

## Electronic Displacement Control - 1/EO

	E	F	Psv - Supply Pressure Port for EO Control
K3VL45/60	3.54 (90)	7.36 (187)	"S" Type: 3/8" O-ring Boss – SAE J1926/1 (9/16-18UNF-2B)
K3VL80	3.27 (83)	7.95 (202)	"S" Type: 3/8" O-ring Boss – SAE J1926/1 (9/16-18UNF-2B)
K3VL112/140	3.07 (78)	9.61 (244)	"S" Type: 3/8" O-ring Boss – SAE J1926/1 (9/16-18UNF-2B)
K3VL200	3.23 (82)	10.20 (259)	"S" Type: 3/8" O-ring Boss – SAE J1926/1 (9/16-18UNF-2B)

## Solenoid Data: Unloading Valve - \*N or \*M

Solenoid Voltage	115VAC	230VAC	6VDC	12VDC	24VDC
Connector Type	ISO4400 / DIN 43650				
Solenoid Resistance at 72°F (22°C)	551Ω	2010Ω	3.5Ω	12.8Ω	45.8Ω
Holding Current at 122°F (50°C)	0.18A	0.09A	1.71A	0.94A	0.52A
Power Consumption	21VA		12W		
Relative Duty Factor	100%				
Response Time at Rated Voltage	30mS				
Protection	IEC144 / DIN 40050 Class IP65				

## 16.0 Proportional Amplifiers

### P-969-0509

Direct DIN solenoid mount, PG9 cable gland connection

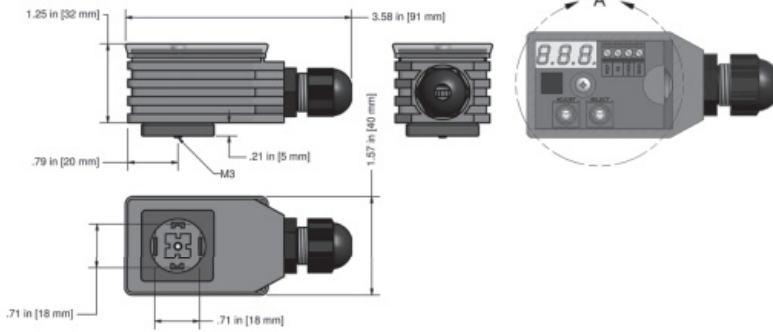

### P-969-0509 Standard Specifications

<b>Operating voltage:</b>	9 to 36 VDC
<b>Maximum output current:</b>	3.00Amps
<b>Input signal:</b>	5V, 10V, 4 to 20mA
<b>Maximum ramp time:</b>	99.5 Sec
<b>PWM / Dither frequency:</b>	40-450Hz
<b>Linearity:</b>	1%
<b>Operating Temperature:</b>	-40° to +75° Celsius
<b>Protection Grade:</b>	IP65

### P-969-0509 Cable Requirements

- Cable rated to 105° Celsius is required.
- Round cable with a diameter range of 4-8mm (0.15 - 0.30") is required to maintain IP65 rating.

### P-969-0510

DIN rail mount

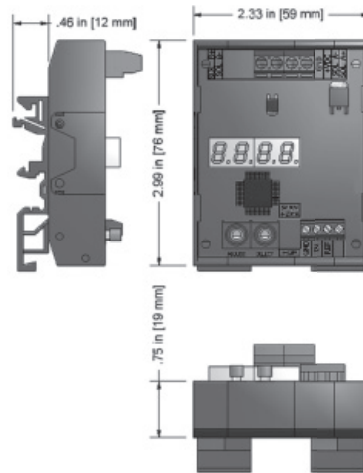

### P-969-0510 Standard Specifications

<b>Operating voltage:</b>	9 to 36 VDC
<b>Maximum output current:</b>	3.00Amps
<b>Input signal:</b>	5V, 10V, 4 to 20mA
<b>Maximum ramp time:</b>	99.5 Sec
<b>PWM / Dither frequency:</b>	40-450Hz
<b>Linearity:</b>	1%
<b>Operating Temperature:</b>	-40° to +80° Celsius

## 16.0 KC-B10-11 Proportional Amplifier

### Specifications

Current Control Pulse Width Modulation	50 ~ 250Hz adjustable
Supply Input Voltage	24VDC +/-20%
Command Input Signal Voltage	0 ~ 5VDC, Max 7.5VDC
Rated Output Current	0.8A (at 5VDC signal input)
Maximum Output Current	1.2A
Power Consumption	Maximum 20VA
Load Resistance	14 ~ 21Ω
Input Impedance	100KΩ
Ambient Temperature Range	32 ~ 122° F (0 ~ 50°C)
Maximum Humidity	90% RH (No dew permissible)
Vibration Resistance (JIS C50250 Type A)	Amplitude: 0.59 in peak to peak (1.5 mm peak to peak) Frequency: 10 ~ 55 Hz 100MW minimum at 500VDC
Insulation	
Current Monitor Output	0.47V/A
Mass	0.041lb (90g)
Gain Adjustment Range	0.8A +/- 0.2A at 5VDC input
Bias Adjustment Range	0 ~ 0.24A
Ramp Time Adjustment Range	(0.1 ~ 5 sec for ramp up from 0 ~ 0.8A) (0.1 ~ 5 sec for ramp down from 0.8A ~ 0)
Linearity	Up to 2% FS
Current Stability	Up to 1.5% FS (ambient temperature change 122°F (50°C)) Up to 2% FS (for supply voltage change +/-20%) Up to 2% FS (load resistance change 14 ~ 21Ω)
Supply Fuse	3.2A Anti-surge plug type PCB mounted

### Installation Drawing

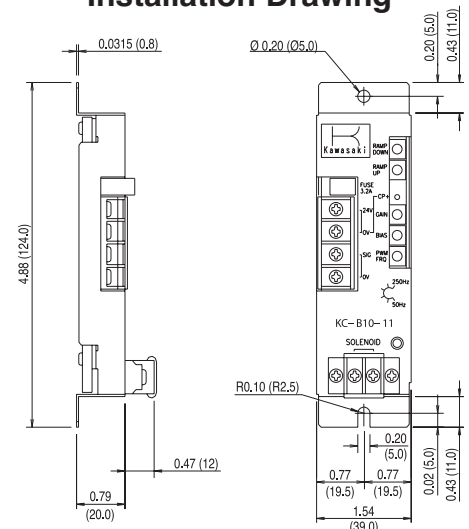

### Kawasaki Precision Machinery (U.S.A.), Inc.

5080 36th Street S.E., Grand Rapids, MI 49512  
(616) 949-6500 • Fax (616) 975-3103  
www.kpm-usa.com

**Kawasaki**  
Hydraulics